

WOODCASEWORK

BASE | WALL | TALL CABINETS

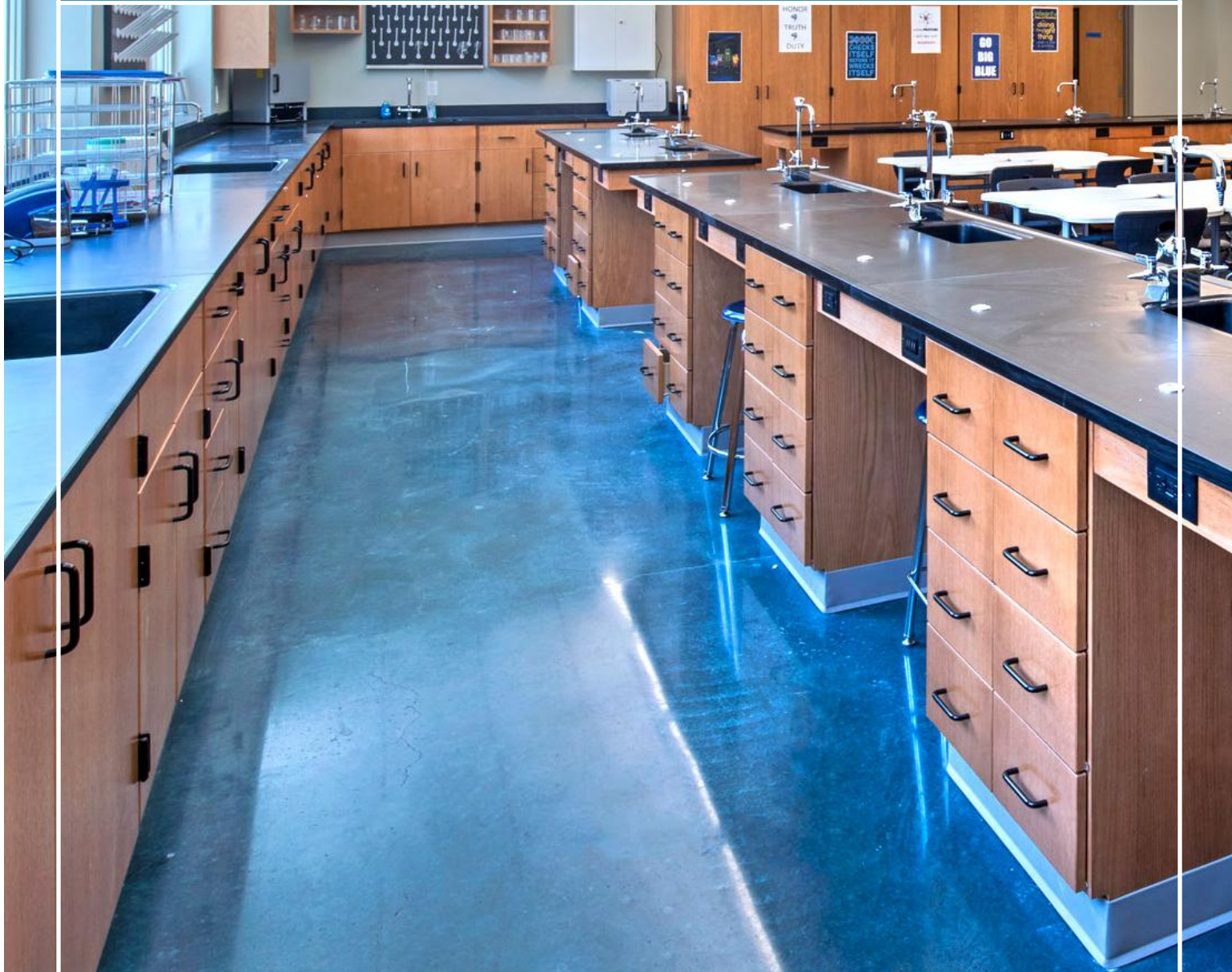



L O N G O

// ASSOCIATES INC.



DISTRIBUTED BY LONGO ASSOCIATES, INC.
WWW.LONGOLABS.COM

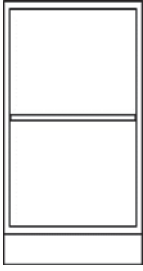
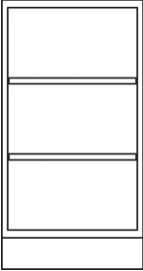

CONTENTS

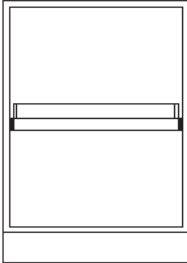
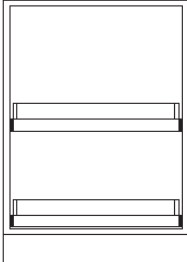
BASE CABINETS	2-42	TALL CABINETS	57-80
Open Base Cabinets	2-3	Open Tall Cabinets	57-58
Door Base Cabinets	4-7	Door Tall Cabinets	59-61
Drawer Base Cabinets	8-19	Wardrobe Cabinets	62-67
Combination Base Cabinets	20-21	Combination Tall Cabinets	68-69
Sink Base Cabinets	22-30	Specialty Tall Cabinets	70-76
Corner Base Cabinets	31-33	Tote Tray Tall Cabinets	77-80
Tote Tray Base Cabinets	34-38		
Specialty Base Cabinets	39-42		
		CONSUMER SCIENCE CABINETS INDEX	81-83
WALL CABINETS	43-56	PLASTIC-LAMINATE CASEWORK	84-97
Open Wall Cabinets	43-44	WOOD SCIENCE CASEWORK AND RELATED PRODUCTS	98-106
Door Wall Cabinets	44-48		
Corner Wall Cabinets	48-55		
Specialty Wall Cabinets	56		

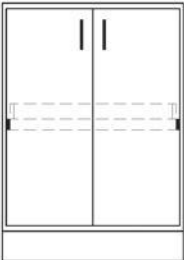
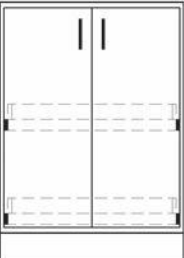
		WIDTHS	HEIGHTS	DEPTHS	DESCRIPTION
B0000 BASE CABINET MOD- IFIER		SPECIFY	SPECIFY	SPECIFY	
B1001 OPEN BASE		12 15 18 21 24 27 30 33 36 39 42 45 48	25.75 29 32 34.5	13.25 15.25 23.25	
B1002 OPEN BASE		12 15 18 21 24 27 30 33 36 39 42 45 48	25.75 29 32 34.5	13.25 15.25 23.25	ONE ADJUSTABLE SHELF
B1003 OPEN BASE		12 15 18 21 24 27 30 33 36 39 42 45 48	25.75 29 32 34.5	13.25 15.25 23.25	TWO ADJUSTABLE SHELVES

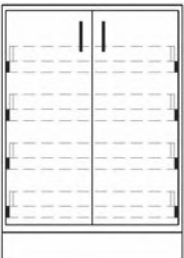

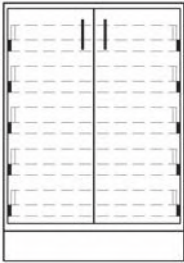
		WIDTHS	HEIGHTS	DEPTHS	DESCRIPTION
B1063 OPEN SUPPLY STORAGE BASE		24			SLIDING TRAY FULL EXTENSION SLIDES
		27			
		30	25.75	23.25	
		33	29		
		36	32		
		39	34.5		
		42			
		45			
48					
B1064 OPEN SUPPLY STORAGE BASE		24			TWO SLIDING TRAYS FULL EXTENSION SLIDES
		27			
		30	25.75	23.25	
		33	29		
		36	32		
		39	34.5		
		42			
		45			
48					

		WIDTHS	HEIGHTS	DEPTHS	DESCRIPTION
B2041 SLIDING TRAY BASE		24			TWO HINGED DOORS SLIDING TRAY FULL EXTENSION SLIDES
		27			
		30	25.75		
		33	29	23.25	
		36	32	28.25	
		39	34.5	34.25	
		42			
45					
48					
B2042 SLIDING TRAY BASE		24			TWO HINGED DOORS TWO SLIDING TRAYS FULL EXTENSION SLIDES
		27			
		30	25.75		
		33	29	23.25	
		36	32	28.25	
		39	34.5	34.25	
		42			
45					
48					
B2043 SLIDING TRAY BASE		24			TWO HINGED DOORS THREE SLIDING TRAYS FULL EXTENSION SLIDES
		27			
		30	25.75		
		33	29	23.25	
		36	32	28.25	
		39	34.5	34.25	
		42			
45					
48					
B2044 SLIDING TRAY BASE		24			TWO HINGED DOORS FOUR SLIDING TRAYS FULL EXTENSION SLIDES
		27			
		30			
		33	29	23.25	
		36	32	28.25	
		39	34.5	34.25	
		42			
45					
48					

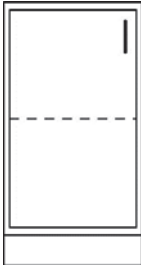
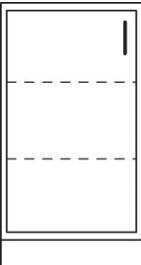
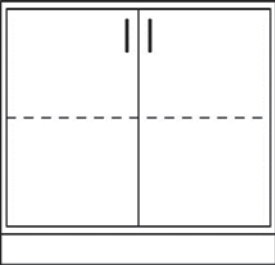
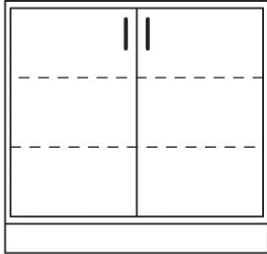

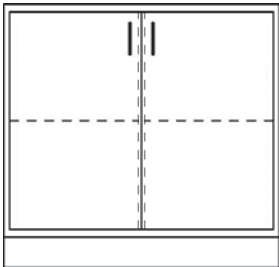
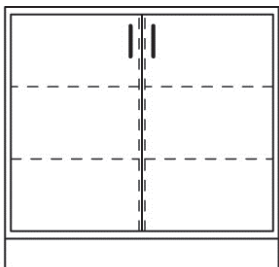
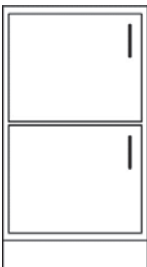
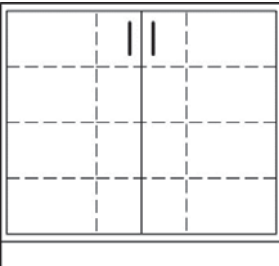
		WIDTHS	HEIGHTS	DEPTHS	DESCRIPTION
B2045 SLIDING TRAY BASE		24			TWO HINGED DOORS FIVE SLIDING TRAYS FULL EXTENSION SLIDES
		27			
		30			
		33	29	23.25	
		36	32	28.25	
		39	34.5	34.25	
		42			
		45			
48					
B2046 SLIDING TRAY BASE		24			TWO HINGED DOORS SIX SLIDING TRAYS FULL EXTENSION SLIDES
		27			
		30			
		33	29	23.25	
		36	32	28.25	
		39	34.5	34.25	
		42			
		45			
48					

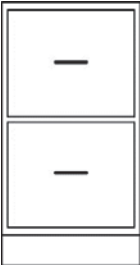
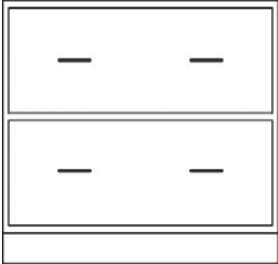

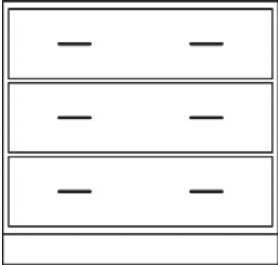
		WIDTHS	HEIGHTS	DEPTHS	DESCRIPTION
B2001 HINGED LEFT B2002 HINGED RIGHT DOOR BASE		12	25.75	23.25	HINGED DOOR ONE ADJUSTABLE SHELF
		15	29		
		18	32		
		21	34.5		
		24			
B2003 HINGED LEFT B2004 HINGED RIGHT DOOR BASE		12	25.75	23.25	HINGED DOOR TWO ADJUSTABLE SHELVES
		15	29		
		18	32		
		21	34.5		
		24			
B2005 DOOR BASE		24	25.75	23.25	TWO HINGED DOORS ONE ADJUSTABLE SHELF
		27			
		30			
		33			
		36			
		39			
		42			
		45			
		48			
		32			
34.5					
B2006 DOOR BASE		24	25.75	23.25	TWO HINGED DOORS TWO ADJUSTABLE SHELVES
		27			
		30			
		33			
		36			
		39			
		42			
		45			
		48			
		32			
34.5					

		WIDTHS	HEIGHTS	DEPTHS	DESCRIPTION
B2007 DOOR BASE		24	25.75 29 32 34.5	23.25	TWO HINGED DOORS TWO ADJUSTABLE SHELVES CENTER PARTITION
		27			
30					
33					
36					
39					
42					
45					
48					
B2008 DOOR BASE		24	25.75 29 32 34.5	23.25	TWO HINGED DOORS FOUR ADJUSTABLE SHELVES CENTER PARTITION
		27			
30					
33					
36					
39					
42					
45					
48					
B2009 HINGED LEFT		12	29 32 34.5	23.25	TWO HINGED DOORS TWO EQUAL COMPARTMENTS
B2010 HINGED RIGHT		15			
PROJECT STORAGE		18			
		21			
		24			
B2011 FLEXIBLE STORAGE		24	29 32 34.5	23.25	TWO HINGED DOORS NINE ADJUSTABLE SHELVES TWO PARTITIONS
		27			
30					
33					
36					
39					
42					
45					
48					

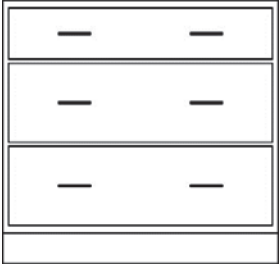
		WIDTHS	HEIGHTS	DEPTHS	DESCRIPTION					
B3001 DRAWER BASE		12	25.75 29 32 34.5	23.25	TWO EQUAL DRAWERS					
		15								
		18								
		21								
		24								
		27								
		30								
		33								
		36								
		39								
		42								
		45								
		48								
B3002 DRAWER BASE		24	25.75 29 32 34.5	23.25	TWO EQUAL DRAWERS					
		27								
		30								
		33								
		36								
		39								
		42								
		45								
		48								
		B3003 DRAWER BASE					12	25.75 29 32 34.5	23.25	THREE EQUAL DRAWERS
							15			
							18			
							21			
24										
27										
30										
33										
36										
39										
42										
45										
48										
B3004 DRAWER BASE		24	25.75 29 32 34.5	23.25	THREE EQUAL DRAWERS					
		27								
		30								
		33								
		36								
		39								
		42								
		45								
		48								

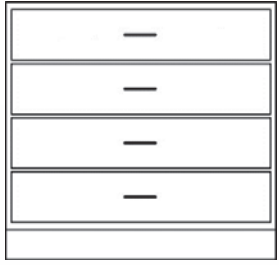
DRAWER BASE CABINETS

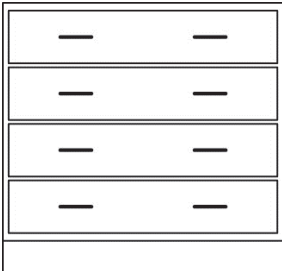
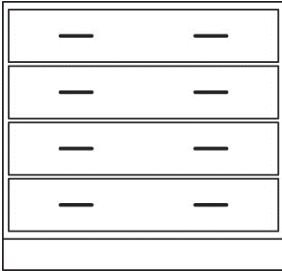
		WIDTHS	HEIGHTS	DEPTHS	DESCRIPTION					
B3005 DRAWER BASE		12	25.75 29 32 34.5	23.25	THREE DRAWERS					
		15								
		18								
		21								
		24								
		27								
		30								
		33								
		36								
		39								
		42								
		45								
		48								
B3006 DRAWER BASE		24	25.75 29 32 34.5	23.25	THREE DRAWERS					
		27								
		30								
		33								
		36								
		39								
		42								
		45								
		48								
		B3007 DRAWER BASE					12	25.75 29 32 34.5	23.25	FOUR EQUAL DRAWERS
							15			
							18			
							21			
24										
27										
30										
33										
36										
39										
42										
45										
48										
B3046 PROJECT STORAGE DRAWER BASE		24	25.75 29 32 34.5	23.25 28.25 34.25	FOUR EQUAL FULL DEPTH DRAWERS DRAWERS W/HOODS FULL EXTENSION SLIDES					
		27								
		30								
		33								
		36								
		39								
		42								
		45								
		48								

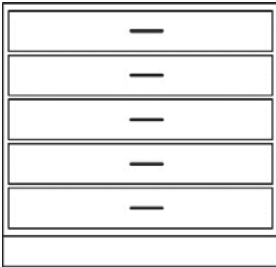

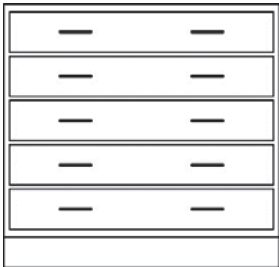
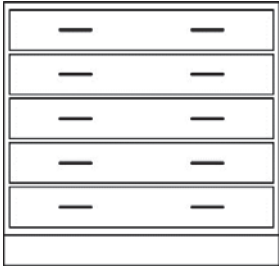
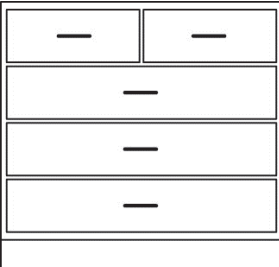
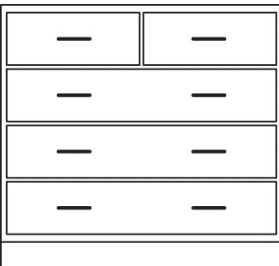

		WIDTHS	HEIGHTS	DEPTHS	DESCRIPTION
B3008 DRAWER BASE		24			FOUR EQUAL DRAWERS
		27			
30	25.75	23.25			
33	29				
36	32				
39	34.5				
42					
45					
48					
B3047 PROJECT STORAGE DRAWER BASE		24			FOUR EQUAL FULL DEPTH DRAWERS DRAWERS W/HOODS FULL EXTENSION SLIDES
		27			
30	25.75	23.25			
33	29	28.25			
36	32	34.25			
39	34.5				
42					
45					
48					
B3009 DRAWER BASE		12			FIVE EQUAL DRAWERS
		15			
18					
21					
24					
27	29	23.25			
30	32				
33	34.5				
36					
39					
42					
45					
48					
B3038 PROJECT STORAGE DRAWER BASE		24			FIVE EQUAL FULL DEPTH DRAWERS DRAWERS W/HOODS FULL EXTENSION SLIDES
		27			
30					
33	29	23.25			
36	32	28.25			
39	34.5	34.25			
42					
45					
48					

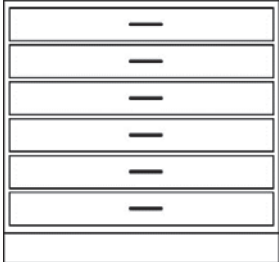
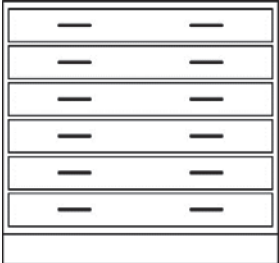
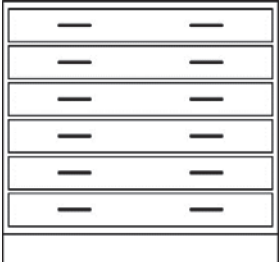
DRAWER BASE CABINETS

		WIDTHS	HEIGHTS	DEPTHS	DESCRIPTION
B3010 DRAWER BASE		24			FIVE EQUAL DRAWERS
		27			
		30			
		33	29	23.25	
		36	32		
		39	34.5		
		42			
45					
48					
B3039 PROJECT STORAGE DRAWER BASE		24			FIVE EQUAL FULL DEPTH DRAWERS DRAWERS W/HOODS FULL EXTENSION SLIDES
		27			
		30			
		33	29	23.25	
		36	32	28.25	
		39	34.5	34.25	
		42			
45					
48					
B3011 DRAWER BASE		24			FIVE DRAWERS
		27			
		30			
		33	29	23.25	
		36	32		
		39	34.5		
		42			
45					
48					
B3012 DRAWER BASE		24			FIVE DRAWERS
		27			
		30			
		33	29	23.25	
		36	32		
		39	34.5		
		42			
45					
48					

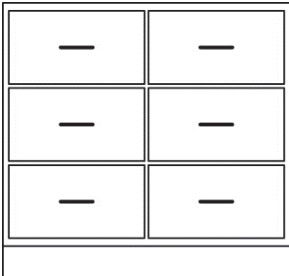

		WIDTHS	HEIGHTS	DEPTHS	DESCRIPTION			
B3013 DRAWER BASE		12			SIX EQUAL DRAWERS			
		15						
		18						
		21						
		24						
		27	29	23.25				
		30	32					
		33	34.5					
		36						
		39						
		42						
		45						
		48						
B3040 PROJECT STORAGE DRAWER BASE		24			SIX EQUAL FULL DEPTH DRAWERS DRAWERS W/HOODS FULL EXTENSION SLIDES			
		27						
		30						
		33	29	23.25				
		36	32	28.25				
		39	34.5	34.25				
		42						
		45						
		48						
		B3014 DRAWER BASE		24				SIX EQUAL DRAWERS
				27				
				30				
				33		29	23.25	
36	32							
39	34.5							
42								
45								
48								
B3041 PROJECT STORAGE DRAWER BASE				24			SIX EQUAL FULL DEPTH DRAWERS DRAWERS W/HOODS FULL EXTENSION SLIDES	
				27				
				30				
				33	29	23.25		
		36	32	28.25				
		39	34.5	34.25				
		42						
		45						
		48						

DRAWER BASE CABINETS

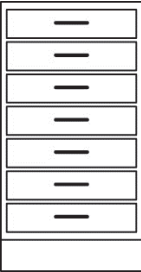
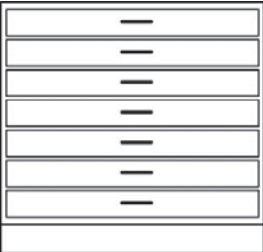
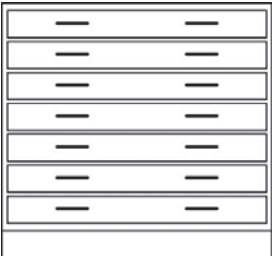
		WIDTHS	HEIGHTS	DEPTHS	DESCRIPTION
B3015 DRAWER BASE		24	29	23.25	SIX EQUAL DRAWERS
		27			
		30	32		
		33	34.5		
		36			
		39			
		42			
		45			
		48			
B3016 DRAWER/ OPEN BASE		24	29	23.25	SIX EQUAL DRAWERS OPEN COMPARTMENT AT TOP
		27			
		30	32		
		33	34.5		
		36			
		39			
		42			
		45			
		48			
B3017 DRAWER BASE		24	29	23.25	SIX DRAWERS
		27			
		30	32		
		33	34.5		
		36			
		39			
		42			
		45			
		48			
B3018 DRAWER BASE		24	29	23.25	SIX DRAWERS
		27			
		30	32		
		33	34.5		
		36			
		39			
		42			
		45			
		48			

		WIDTHS	HEIGHTS	DEPTHS	DESCRIPTION
B3019 DRAWER BASE		12	32 34.5	23.25	SEVEN EQUAL DRAWERS
		15			
		18			
		21			
		24			
		27			
		30			
		33			
		36			
		39			
42					
45					
48					
B3042 PROJECT STORAGE DRAWER BASE		24	32 34.5	23.25 28.25 34.25	SEVEN EQUAL FULL DEPTH DRAWERS DRAWERS W/HOODS FULL EXTENSION SLIDES
		27			
		30			
		33			
		36			
		39			
		42			
		45			
		48			
		B3020 DRAWER BASE			
27					
30					
33					
36					
39					
42					
45					
48					
B3043 PROJECT STORAGE DRAWER BASE			24	32 34.5	23.25 28.25 34.25
		27			
		30			
		33			
		36			
		39			
		42			
		45			
		48			

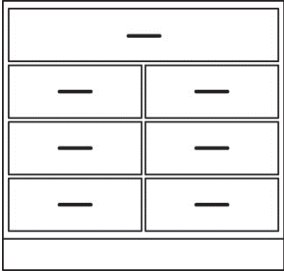
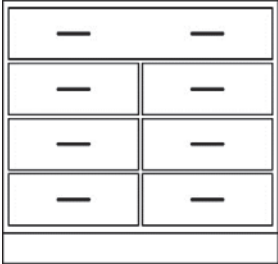
DRAWER BASE CABINETS

		WIDTHS	HEIGHTS	DEPTHS	DESCRIPTION
B3021 DRAWER BASE		24	29 32 34.5	23.25	SEVEN DRAWERS
		27			
		30			
		33			
		36			
		39			
		42			
45					
48					
B3022 DRAWER BASE		24	29 32 34.5	23.25	SEVEN DRAWERS
		27			
		30			
		33			
		36			
		39			
		42			
45					
48					
B3023 DRAWER BASE		24	32 34.5	23.25	SEVEN DRAWERS
		27			
		30			
		33			
		36			
		39			
		42			
45					
48					
B3024 DRAWER BASE		24	32 34.5	23.25	SEVEN DRAWERS
		27			
		30			
		33			
		36			
		39			
		42			
45					
48					

		WIDTHS	HEIGHTS	DEPTHS	DESCRIPTION
B3025 DRAWER BASE		24 27 30 33 36 39 42 45 48	32 34.5	23.25	SEVEN DRAWERS
B3026 DRAWER BASE		24 27 30 33 36 39 42 45 48	32 34.5	23.25	SEVEN DRAWERS
B3027 DRAWER BASE		24 27 30 33 36 39 42 45 48	32 34.5	23.25	SEVEN DRAWERS
B3028 DRAWER BASE		24 27 30 33 36 39 42 45 48	32 34.5	23.25	SEVEN DRAWERS

DRAWER BASE CABINETS

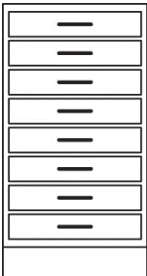
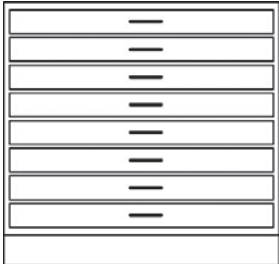
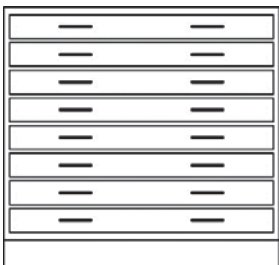
		WIDTHS	HEIGHTS	DEPTHS	DESCRIPTION
B3029 DRAWER BASE		12	32 34.5	23.25	EIGHT EQUAL DRAWERS
		15			
		18			
		21			
		24			
		27			
		30			
		33			
		36			
		39			
42					
45					
48					
B3044 PROJECT STORAGE DRAWER BASE		12	32 34.5	23.25 28.25 34.25	EIGHT EQUAL FULL DEPTH DRAWERS DRAWERS W/HOODS FULL EXTENSION SLIDES
		15			
		18			
		21			
		24			
		27			
		30			
		33			
		36			
		39			
42					
45					
48					
B3030 DRAWER BASE		24	32 34.5	23.25	EIGHT EQUAL DRAWERS
		27			
		30			
		33			
		36			
		39			
		42			
		45			
		48			
		B3045 PROJECT STORAGE DRAWER BASE			
27					
30					
33					
36					
39					
42					
45					
48					

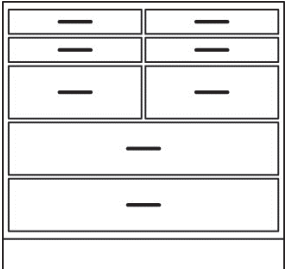
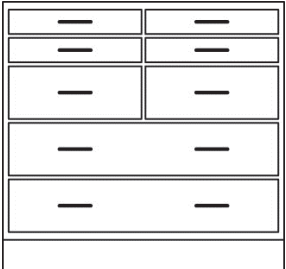
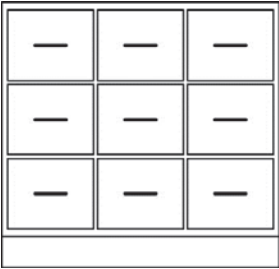
		WIDTHS	HEIGHTS	DEPTHS	DESCRIPTION
B3031 DRAWER BASE		24	29 32 34.5	23.25	EIGHT EQUAL DRAWERS
		27			
30					
33					
36					
39					
42					
45					
48					
B3032 DRAWER BASE		24	32 34.5	23.25	EIGHT DRAWERS
		27			
30					
33					
36					
39					
42					
45					
48					
B3033 DRAWER BASE		24	32 34.5	23.25	EIGHT DRAWERS
		27			
30					
33					
36					
39					
42					
45					
48					
B3034 DRAWER BASE		36	29 32 34.5	23.25	NINE EQUAL DRAWERS
		39			
42					
45					
48					

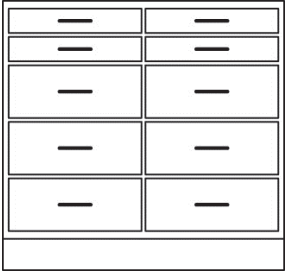
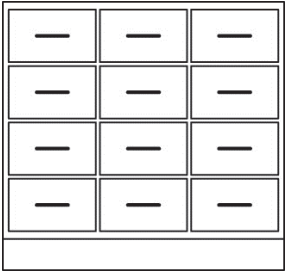
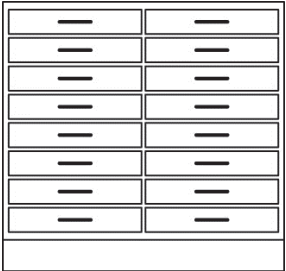
		WIDTHS	HEIGHTS	DEPTHS	DESCRIPTION
B3035 DRAWER BASE		24	32 34.5	23.25	TEN DRAWERS
		27 30 33 36 39 42 45 48			
B3036 DRAWER BASE		36	29 32 34.5	23.25	TWELVE EQUAL DRAWERS
		39 42 45 48			
B3037 DRAWER BASE		24	32 34.5	23.25	SIXTEEN EQUAL DRAWERS
		27 30 33 36 39 42 45 48			

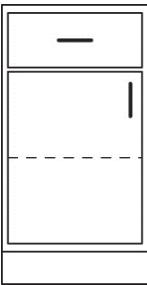
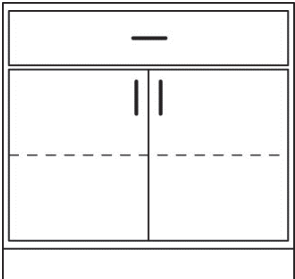
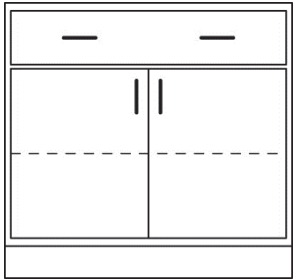
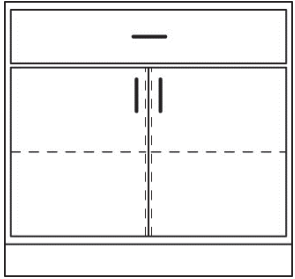
		WIDTHS	HEIGHTS	DEPTHS	DESCRIPTION
B4001 HINGED LEFT B4002 HINGED RIGHT DOOR DRAWER BASE		12	25.75 29 32 34.5	23.25	HINGED DOOR DRAWER ONE ADJUSTABLE SHELF
		15			
		18			
		21			
		24			
B4003 DOOR DRAWER BASE		24	25.75 29 32 34.5	23.25	TWO HINGED DOORS DRAWER ONE ADJUSTABLE SHELF
		27			
		30			
		33			
		36			
		39			
		42			
		45			
48					
B4004 DOOR DRAWER BASE		24	25.75 29 32 34.5	23.25	TWO HINGED DOORS DRAWER ONE ADJUSTABLE SHELF
		27			
		30			
		33			
		36			
		39			
		42			
		45			
48					
B4005 DOOR DRAWER BASE		24	25.75 29 32 34.5	23.25	TWO HINGED DOORS DRAWER TWO ADJUSTABLE SHELVES CENTER PARTITION
		27			
		30			
		33			
		36			
		39			
		42			
		45			
48					

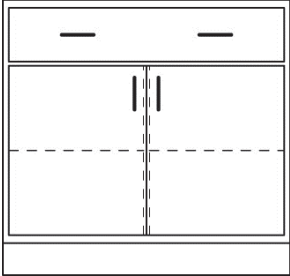
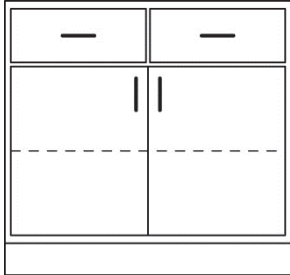
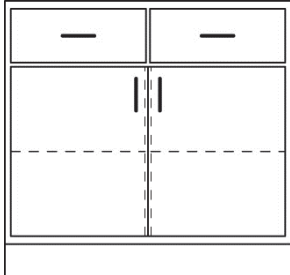

DRAWER BASE CABINETS

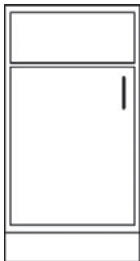
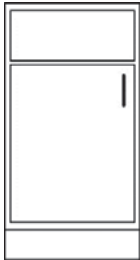
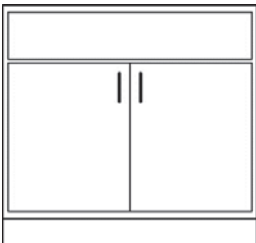
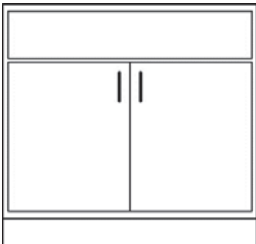
		WIDTHS	HEIGHTS	DEPTHS	DESCRIPTION
B4006 DOOR DRAWER BASE		24			TWO HINGED DOORS DRAWER TWO ADJUSTABLE SHELVES CENTER PARTITION
		27	25.75	23.25	
		30	29		
		33	32		
		36	34.5		
		39			
		42			
45					
48					
B4007 DOOR DRAWER BASE		24			TWO HINGED DOORS TWO DRAWERS ONE ADJUSTABLE SHELF
		27	25.75	23.25	
		30	29		
		33	32		
		36	34.5		
		39			
		42			
45					
48					
B4008 DOOR DRAWER BASE		24			TWO HINGED DOORS TWO DRAWERS TWO ADJUSTABLE SHELVES CENTER PARTITION
		27	25.75	23.25	
		30	29		
		33	32		
		36	34.5		
		39			
		42			
45					
48					

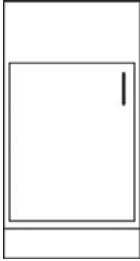
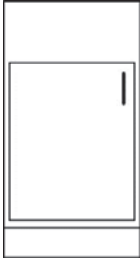
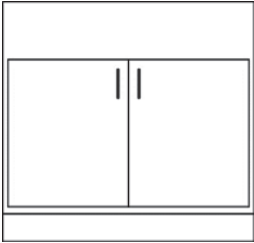
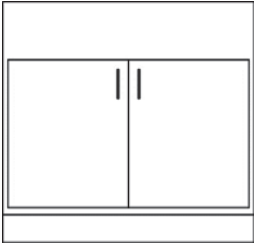

		WIDTHS	HEIGHTS	DEPTHS	DESCRIPTION
B5001 HINGED LEFT B5002 HINGED RIGHT SINK BASE		12	25.75	23.25	HINGED DOOR REMOVABLE BACK PANEL BLANK DRAWER HEAD SUFFIX -DD FOR DBL DEPTH CABINET W/DOORS BOTH SIDES (VERIFY HINGING AT REAR)
		15	29		
		18	32		
		21	34.5		
		24			
B5017 HINGED LEFT B5018 HINGED RIGHT SINK BASE		12	25.75	23.25	HINGED DOOR REMOVABLE BACK PANEL REMOVABLE BOTTOM BLANK DRAWER HEAD SUFFIX -DD FOR DBL DEPTH CABINET W/DOORS BOTH SIDES (VERIFY HINGING AT REAR)
		15	29		
		18	32		
		21	34.5		
		24			
B5003 SINK BASE		24	25.75	23.25	TWO HINGED DOORS REMOVABLE BACK PANEL BLANK DRAWER HEAD SUFFIX -DD FOR DBL DEPTH CABINET W/DOORS BOTH SIDES
		27			
		30			
		33			
		36			
		39			
		42			
		45			
48					
B5019 SINK BASE		24	25.75	23.25	TWO HINGED DOORS REMOVABLE BACK PANEL REMOVABLE BOTTOM BLANK DRAWER HEAD SUFFIX -DD FOR DBL DEPTH CABINET W/DOORS BOTH SIDES
		27			
		30			
		33			
		36			
		39			
		42			
		45			
48					

SINK BASE CABINETS

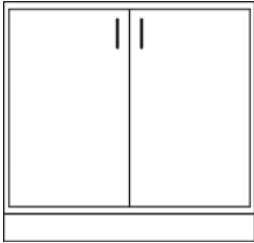
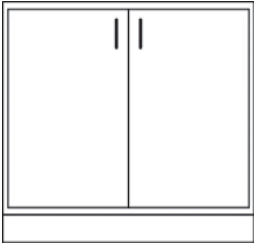
		WIDTHS	HEIGHTS	DEPTHS	DESCRIPTION
<p>B5004 HINGED RIGHT</p> <p>B5005 HINGED LEFT</p> <p>SINK BASE</p>		<p>12 15 18 21 24</p>	<p>25.75 29 32 34.5</p>	<p>23.25</p>	<p>HINGED DOOR REMOVABLE BACK PANEL HEAD RAIL ABOVE DOOR SUFFIX -DD FOR DBL DEPTH CABINET W/DOORS BOTH SIDES (VERIFY HINGING AT REAR)</p>
<p>B5020 HINGED RIGHT</p> <p>B5021 HINGED LEFT</p> <p>SINK BASE</p>		<p>12 15 18 21 24</p>	<p>25.75 29 32 34.5</p>	<p>23.25</p>	<p>HINGED DOOR REMOVABLE BACK PANEL REMOVABLE BOTTOM HEAD RAIL ABOVE DOOR SUFFIX -DD FOR DBL DEPTH CABINET W/DOORS BOTH SIDES (VERIFY HINGING AT REAR)</p>
<p>B5006</p> <p>SINK BASE</p>		<p>24 27 30 33 36 39 42 45 48</p>	<p>25.75 29 32 34.5</p>	<p>23.25</p>	<p>TWO HINGED DOORS REMOVABLE BACK PANEL HEAD RAIL ABOVE DOORS SUFFIX -DD FOR DBL DEPTH CABINET W/DOORS BOTH SIDES</p>
<p>B5022</p> <p>SINK BASE</p>		<p>24 27 30 33 36 39 42 45 48</p>	<p>25.75 29 32 34.5</p>	<p>23.25</p>	<p>TWO HINGED DOORS REMOVABLE BACK PANEL REMOVABLE BOTTOM HEAD RAIL ABOVE DOORS SUFFIX -DD FOR DBL DEPTH CABINET W/DOORS BOTH SIDES</p>





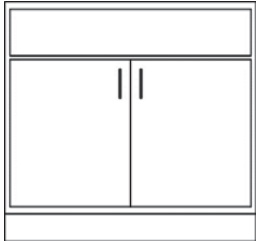
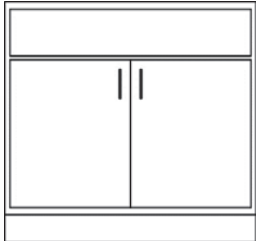

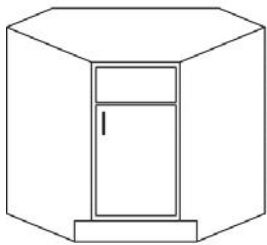
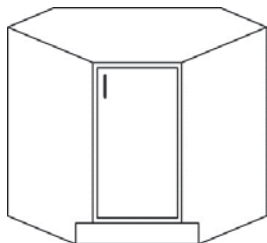

		WIDTHS	HEIGHTS	DEPTHS	DESCRIPTION
B5007 HINGED LEFT B5008 HINGED RIGHT SINK BASE		12	25.75	23.25	HINGED DOOR REMOVABLE BACK PANEL SUFFIX -DD FOR DBL DEPTH CABINET W/DOORS BOTH SIDES (VERIFY HINGING AT REAR)
		15	29		
18	32				
21	34.5				
24					
B5023 HINGED LEFT B5024 HINGED RIGHT SINK BASE		12	25.75	23.25	HINGED DOOR REMOVABLE BACK PANEL REMOVABLE BOTTOM SUFFIX -DD FOR DBL DEPTH CABINET W/DOORS BOTH SIDES (VERIFY HINGING AT REAR)
		15	29		
18	32				
21	34.5				
24					
B5009 SINK BASE		24	25.75	23.25	TWO HINGED DOORS REMOVABLE BACK PANEL SUFFIX -DD FOR DBL DEPTH CABINET W/DOORS BOTH SIDES
		27	29		
30	32				
33	34.5				
36					
39					
42					
45					
48					
B5025 SINK BASE		24	25.75	23.25	TWO HINGED DOORS REMOVABLE BACK PANEL REMOVABLE BOTTOM SUFFIX -DD FOR DBL DEPTH CABINET W/DOORS BOTH SIDES
		27	29		
30	32				
33	34.5				
36					
39					
42					
45					
48					

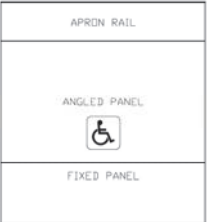
SINK BASE CABINETS

		WIDTHS	HEIGHTS	DEPTHS	DESCRIPTION
<p>B5010 HINGED RIGHT</p> <p>B5011 HINGED LEFT</p> <p>SINK BASE</p>		<p>12 15 18 21 24</p>	<p>25.75 29 32 34.5</p>	<p>23.25</p>	<p>HINGED DOOR REMOVABLE BACK PANEL RECESSED PANEL ABOVE DOOR SUFFIX -DD FOR DBL DEPTH CABINET W/DOORS BOTH SIDES (VERIFY HINGING AT REAR)</p>
<p>B5026 HINGED RIGHT</p> <p>B5027 HINGED LEFT</p> <p>SINK BASE</p>		<p>12 15 18 21 24</p>	<p>25.75 29 32 34.5</p>	<p>23.25</p>	<p>HINGED DOOR REMOVABLE BACK PANEL REMOVABLE BOTTOM RECESSED PANEL ABOVE DOOR SUFFIX -DD FOR DBL DEPTH CABINET W/DOORS BOTH SIDES (VERIFY HINGING AT REAR)</p>
<p>B5012</p> <p>SINK BASE</p>		<p>24 27 30 33 36 39 42 45 48</p>	<p>25.75 29 32 34.5</p>	<p>23.25</p>	<p>TWO HINGED DOORS REMOVABLE BACK PANEL RECESSED PANEL ABOVE DOOR SUFFIX -DD FOR DBL DEPTH CABINET W/DOORS BOTH SIDES</p>
<p>B5028</p> <p>SINK BASE</p>		<p>24 27 30 33 36 39 42 45 48</p>	<p>25.75 29 32 34.5</p>	<p>23.25</p>	<p>TWO HINGED DOORS REMOVABLE BACK PANEL REMOVABLE BOTTOM RECESSED PANEL ABOVE DOOR SUFFIX -DD FOR DBL DEPTH CABINET W/DOORS BOTH SIDES</p>

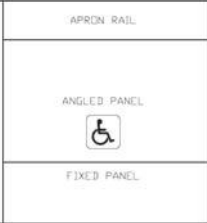

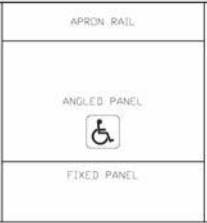

		WIDTHS	HEIGHTS	DEPTHS	DESCRIPTION
<p>B5013 HINGED LEFT</p> <p>B5014 HINGED RIGHT</p> <p>CORNER SINK BASE</p>		<p>36 39 42</p>	<p>25.75 29 32 34.5</p>	<p>23.25</p>	<p>HINGED DOOR REMOVABLE BACK PANEL ONE BLANK DRAWER HEAD WIDTH = WALL SPACE REQUIRED</p>
<p>B5015 HINGED LEFT</p> <p>B5016 HINGED RIGHT</p> <p>CORNER SINK BASE</p>		<p>36 39 42</p>	<p>25.75 29 32 34.5</p>	<p>23.25</p>	<p>HINGED DOOR REMOVABLE BACK PANEL WIDTH = WALL SPACE REQUIRED</p>

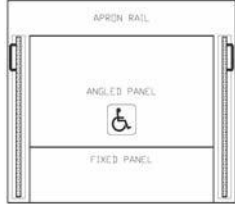

SINK BASE CABINETS

		WIDTHS	HEIGHTS	DEPTHS	DESCRIPTION
<p>D5001</p> <p>ADA SINK PANEL ASSEMBLY</p>  <p>APRON RAIL ANGLED PANEL FIXED PANEL</p> 	30 33 36 39 42 45 48	*29 32	23.25	<p>APRON RAIL ANGLED REMOVABLE PANEL FIXED PANEL 27" KNEE CLEARANCE (*SUITABLE FOR STUDENTS 6-12 ONLY)</p>	
<p>D5002</p> <p>ADA SINK PANEL ASSEMBLY</p>  <p>APRON RAIL ANGLED PANEL FIXED PANEL</p> 	30.75 33 36 39 42 45 48	*29 32	23.25	<p>APRON RAIL ANGLED REMOVABLE PANEL FIXED PANEL RIGHT END PANEL 27" KNEE CLEARANCE (*SUITABLE FOR STUDENTS 6-12 ONLY)</p>	
<p>D5003</p> <p>ADA SINK PANEL ASSEMBLY</p>  <p>APRON RAIL ANGLED PANEL FIXED PANEL</p> 	30.75 33 36 39 42 45 48	*29 32	23.25	<p>APRON RAIL ANGLED REMOVABLE PANEL FIXED PANEL LEFT END PANEL 27" KNEE CLEARANCE (*SUITABLE FOR STUDENTS 6-12 ONLY)</p>	
<p>D5004</p> <p>ADA SINK PANEL ASSEMBLY</p>  <p>APRON RAIL ANGLED PANEL FIXED PANEL</p> 	31.5 33 36 39 42 45 48	*29 32	23.25	<p>APRON RAIL ANGLED REMOVABLE PANEL FIXED PANEL LEFT & RIGHT END PANEL 27" KNEE CLEARANCE (*SUITABLE FOR STUDENTS 6-12 ONLY)</p>	

		WIDTHS	HEIGHTS	DEPTHS	DESCRIPTION
D5006 ADA SINK PANEL ASSEMBLY		30 33 36 39 42 45 48	32	23.25	APRON RAIL ANGLED REMOVABLE PANEL FIXED PANEL 29" KNEE CLEARANCE
D5007 ADA SINK PANEL ASSEMBLY		30.75 33 36 39 42 45 48	32	23.25	APRON RAIL ANGLED REMOVABLE PANEL FIXED PANEL LEFT END PANEL 29" KNEE CLEARANCE
D5008 ADA SINK PANEL ASSEMBLY		30.75 33 36 39 42 45 48	32	23.25	APRON RAIL ANGLED REMOVABLE PANEL FIXED PANEL RIGHT END PANEL 29" KNEE CLEARANCE
D5009 ADA SINK PANEL ASSEMBLY		31.5 33 36 39 42 45 48	32	23.25	APRON RAIL ANGLED REMOVABLE PANEL FIXED PANEL LEFT AND RIGHT END PANEL 29" KNEE CLEARANCE

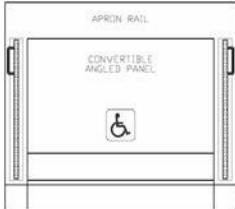
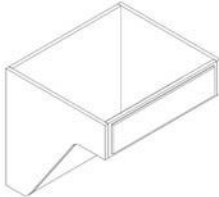
SINK BASE CABINETS

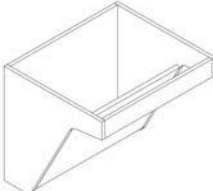
		WIDTHS	HEIGHTS	DEPTHS	DESCRIPTION
D5100 ADA POCKET DOOR SINK BASE 		39			TWO POCKET DOORS ANGLED REMOVABLE PANEL 27" KNEE CLEARANCE (*SUITABLE FOR STUDENTS 6-12 ONLY)
		42	*29	23.25	
		45	32		
		48			
D5130 ADA POCKET DOOR SINK BASE 		39			TWO POCKET DOORS FULL TOE KICK CONVERTIBLE BOTTOM FLIPS UP AS ANGLED PANEL 24" KNEE CLEARANCE (*SUITABLE FOR STUDENTS 6-12 ONLY)
		42	*29	23.25	
		45			
		48			
D5140 ADA POCKET DOOR SINK BASE 		39			TWO POCKET DOORS FULL TOE KICK CONVERTIBLE BOTTOM FLIPS UP AS ANGLED PANEL 27" KNEE CLEARANCE
		42	32	23.25	
		45			
		48			
B5210 STANDARD SINK SKIRT ASSEMBLY		24			ANGLED REMOVABLE PANEL LEFT & RIGHT END PANEL
		27			
		30			
		33			
		36	23.75	23.25	
		39		28.25	
		42			
		45			
		48			

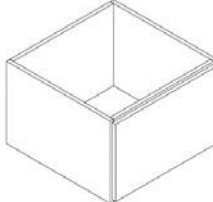
		WIDTHS	HEIGHTS	DEPTHS	DESCRIPTION
<p>D5210</p> <p>ADA SINK SKIRT ASSEMBLY</p>  		24 27 30 33 36 39 42 45 48	23.75	23.25 28.25	5" APRON RAIL ANGLED REMOVABLE PANEL LEFT & RIGHT END PANELS MOUNT 9" ABOVE FINISH FLOOR
<p>B5250</p> <p>BOX SINK SKIRT ASSEMBLY</p> 		24 27 30 33 36 39 42 45 48	23.75	23.25 28.25	REMOVABLE FRONT PANEL

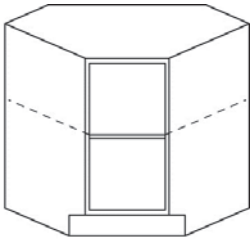
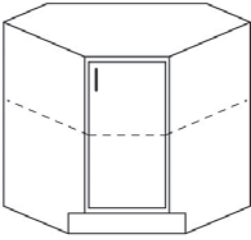
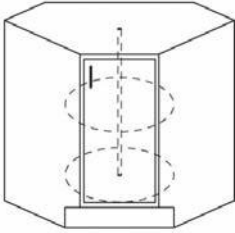
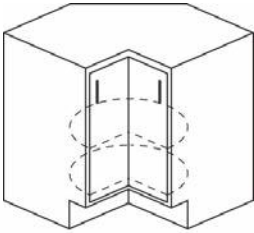

CORNER BASE CABINETS

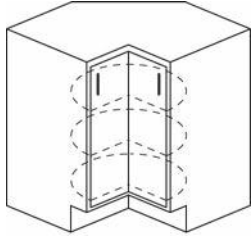
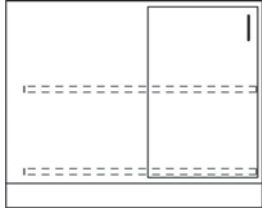
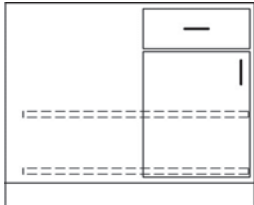
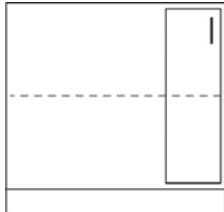
		WIDTHS	HEIGHTS	DEPTHS	DESCRIPTION
<p>B6001</p> <p>CORNER OPEN BASE</p> 	<p>36 39 42</p>	<p>25.75 29 32 34.5</p>	<p>23.25</p>	<p>ONE ADJUSTABLE SHELF WIDTH = WALL SPACE REQUIRED</p>	
<p>B6002 HINGED RIGHT</p> <p>B6003 HINGED LEFT</p> <p>CORNER BASE</p> 	<p>36 39 42</p>	<p>25.75 29 32 34.5</p>	<p>23.25</p>	<p>HINGED DOOR ONE ADJUSTABLE SHELF WIDTH = WALL SPACE REQUIRED</p>	
<p>B6004 HINGED RIGHT</p> <p>B6005 HINGED LEFT</p> <p>CORNER CAROUSEL BASE</p> 	<p>36 39 42</p>	<p>29 32 34.5</p>	<p>23.25</p>	<p>HINGED DOOR TWO REVOLVING SHELVES WIDTH = WALL SPACE REQUIRED</p>	
<p>B6006</p> <p>CORNER CAROUSEL BASE</p> 	<p>36 39 42</p>	<p>29 32 34.5</p>	<p>23.25</p>	<p>TWO REVOLVING DOORS TWO REVOLVING SHELVES WIDTH = WALL SPACE REQUIRED</p>	

		WIDTHS	HEIGHTS	DEPTHS	DESCRIPTION
<p>B6007 CORNER CAROUSEL BASE</p> 		36 39 42	32 34.5	23.25	TWO REVOLVING DOORS TWO REVOLVING SHELVES WIDTH = WALL SPACE REQUIRED
<p>B6008 PANEL RIGHT</p> <p>B6009 PANEL LEFT</p> <p>DEAD CORNER TURNOUT BASE</p> 		*42 45 48	32 34.5	23.25	DOOR HINGED TO PANEL TWO TURNOUT SHELVES WIDTH = WALL SPACE REQUIRED (*42" REQUIRES 45" WALL SPACE)
<p>B6010 PANEL RIGHT</p> <p>B6011 PANEL LEFT</p> <p>DEAD CORNER TURNOUT BASE</p> 		*42 45 48	32 34.5	23.25	DOOR HINGED TO PANEL ONE DRAWER TWO TURNOUT SHELVES WIDTH = WALL SPACE REQUIRED (*42" REQUIRES 45" WALL SPACE)
<p>B6012 PANEL RIGHT</p> <p>B6013 PANEL LEFT</p> <p>DEAD CORNER BASE</p> 		36 39 42 45 48	25.75 29 32 34.5	23.25	DOOR HINGED TO PANEL ONE ADJUSTABLE SHELF SPECIFY DOOR OPENING SIZE: 10.5", 13.5", 16.5", 19.5", OR 22.5"

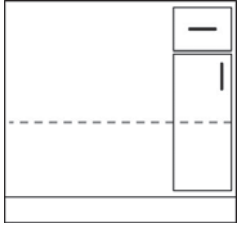
CORNER BASE CABINETS

		WIDTHS	HEIGHTS	DEPTHS	DESCRIPTION
<p>B6014 HINGED RIGHT</p> <p>B6015 HINGED LEFT</p> <p>DEAD CORNER BASE</p>		36			<p>DOOR HINGED TO PANEL ONE DRAWER ABOVE ONE ADJUSTABLE SHELF SPECIFY DOOR OPENING SIZE: 10.5", 13.5", 16.5", 19.5", OR 22.5"</p>
		39	29		
		42	32	23.25	
		45	34.5		
		48			

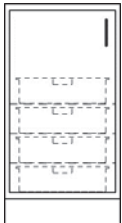
		WIDTHS	HEIGHTS	DEPTHS	DESCRIPTION
<p>B7001 HINGED LEFT</p> <p>B7002 HINGED RIGHT</p> <p>TOTE TRAY BASE</p>		<p>12</p> <p>15</p> <p>18</p>	<p>25.75</p> <p>29</p> <p>32</p> <p>34.5</p>	<p>23.25</p>	<p>HINGED DOOR</p> <p>ONE DRAWER</p> <p>NOMINAL TOTE SIZES</p> <p>12"- (3) 7.5" WIDE TOTE TRAYS</p> <p>15"- (3) 9.5" WIDE TOTE TRAYS</p> <p>18"- (3) 13.5" WIDE TOTE TRAYS</p> <p>ORDER TOTES SEPARATELY</p>
<p>B7003 HINGED LEFT</p> <p>B7004 HINGED RIGHT</p> <p>TOTE TRAY BASE</p>		<p>12</p> <p>15</p> <p>18</p>	<p>32</p> <p>34.5</p>	<p>23.25</p>	<p>HINGED DOOR</p> <p>ONE DRAWER</p> <p>NOMINAL TOTE SIZES</p> <p>12"- (4) 7.5" WIDE TOTE TRAYS</p> <p>15"- (4) 9.5" WIDE TOTE TRAYS</p> <p>18"- (4) 13.5" WIDE TOTE TRAYS</p> <p>ORDER TOTES SEPARATELY</p>
<p>B7005 HINGED LEFT</p> <p>B7006 HINGED RIGHT</p> <p>TOTE TRAY BASE</p>		<p>12</p> <p>15</p> <p>18</p>	<p>25.75</p> <p>29</p> <p>32</p> <p>34.5</p>	<p>23.25</p>	<p>HINGED DOOR</p> <p>NOMINAL TOTE SIZES</p> <p>12"- (4) 7.5" WIDE TOTE TRAYS</p> <p>15"- (4) 9.5" WIDE TOTE TRAYS</p> <p>18"- (4) 13.5" WIDE TOTE TRAYS</p> <p>ORDER TOTES SEPARATELY</p>
<p>B7007 HINGED LEFT</p> <p>B7008 HINGED RIGHT</p> <p>TOTE TRAY BASE</p>		<p>12</p> <p>15</p> <p>18</p>	<p>29</p> <p>32</p> <p>34.5</p>	<p>23.25</p>	<p>HINGED DOOR</p> <p>NOMINAL TOTE SIZES</p> <p>12"- (5) 7.5" WIDE TOTE TRAYS</p> <p>15"- (5) 9.5" WIDE TOTE TRAYS</p> <p>18"- (5) 13.5" WIDE TOTE TRAYS</p> <p>ORDER TOTES SEPARATELY</p>

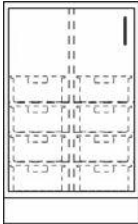
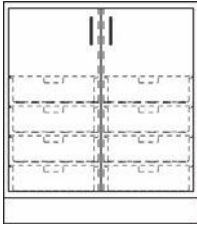
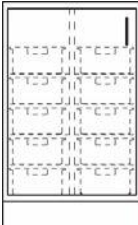

		WIDTHS	HEIGHTS	DEPTHS	DESCRIPTION
<p>B7009 HINGED RIGHT</p> <p>B7010 HINGED LEFT</p> <p>TOTE TRAY BASE</p>		<p>12 15 18</p>	<p>32 34.5</p>	<p>23.25</p>	<p>HINGED DOOR NOMINAL TOTE SIZES 12"- (6) 7.5" WIDE TOTE TRAYS 15"- (6) 9.5" WIDE TOTE TRAYS 18"- (6) 13.5" WIDE TOTE TRAYS ORDER TOTES SEPARATELY</p>
<p>B7011 HINGED RIGHT</p> <p>B7012 HINGED LEFT</p> <p>TOTE TRAY BASE</p>		<p>21 24</p>	<p>25.75 29 32 34.5</p>	<p>23.25</p>	<p>HINGED DOOR NOMINAL TOTE SIZES 21"- (8) 7.5" WIDE TOTE TRAYS 24"- (8) 9.5" WIDE TOTE TRAYS ORDER TOTES SEPARATELY</p>
<p>B7013</p> <p>TOTE TRAY BASE</p>		<p>24 27 30 33</p>	<p>25.75 29 32 34.5</p>	<p>23.25</p>	<p>TWO HINGED DOORS NOMINAL TOTE SIZES 24"- (8) 9.5" WIDE TOTE TRAYS 27"- (8) 9.5" WIDE TOTE TRAYS 30"- (8) 12.5" WIDE TOTE TRAYS 33"- (8) 13.5" WIDE TOTE TRAYS ORDER TOTES SEPARATELY</p>
<p>B7014 HINGED RIGHT</p> <p>B7015 HINGED LEFT</p> <p>TOTE TRAY BASE</p>		<p>21 24</p>	<p>29 32 34.5</p>	<p>23.25</p>	<p>HINGED DOOR NOMINAL TOTE SIZES 21"- (10) 7.5" WIDE TOTE TRAYS 24"- (10) 9.5" WIDE TOTE TRAYS ORDER TOTES SEPARATELY</p>

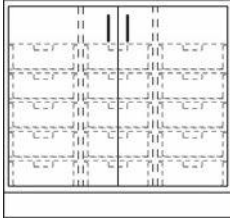
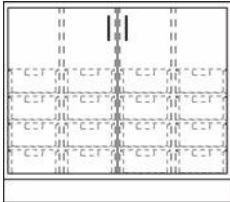
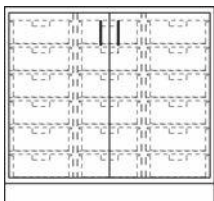
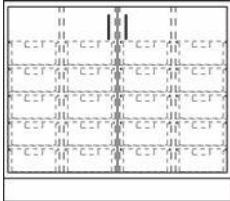

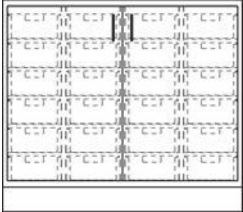
		WIDTHS	HEIGHTS	DEPTHS	DESCRIPTION
B7016 TOTE TRAY BASE		24			TWO HINGED DOORS NOMINAL TOTE SIZES 24"- (10) 9.5" WIDE TOTE TRAYS 27"- (10) 9.5" WIDE TOTE TRAYS 30"- (10) 12.5" WIDE TOTE TRAYS 33"- (10) 13.5" WIDE TOTE TRAYS ORDER TOTES SEPARATELY
		27	29	23.25	
		30	32		
		33	34.5		
B7017 HINGED LEFT B7018 HINGED RIGHT TOTE TRAY BASE		21	32	23.25	HINGED DOOR NOMINAL TOTE SIZES 21"- (12) 7.5" WIDE TOTE TRAYS 24"- (12) 9.5" WIDE TOTE TRAYS ORDER TOTES SEPARATELY
		24	34.5		
B7019 TOTE TRAY BASE		24			TWO HINGED DOORS NOMINAL TOTE SIZES 24"- (12) 9.5" WIDE TOTE TRAYS 27"- (12) 9.5" WIDE TOTE TRAYS 30"- (12) 12.5" WIDE TOTE TRAYS 33"- (12) 13.5" WIDE TOTE TRAYS ORDER TOTES SEPARATELY
		27	32	23.25	
		30	34.5		
		33			
B7020 TOTE TRAY BASE		36	25.75		TWO HINGED DOORS NOMINAL TOTE SIZES 36"- (12) 9.5" WIDE TOTE TRAYS 39"- (12) 9.5" WIDE TOTE TRAYS 42"- (12) 9.5" WIDE TOTE TRAYS 45"- (12) 12.5" WIDE TOTE TRAYS 48"- (12) 13.5" WIDE TOTE TRAYS ORDER TOTES SEPARATELY
		39	29	23.25	
		42	32		
		45	34.5		
		48			

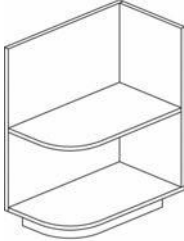
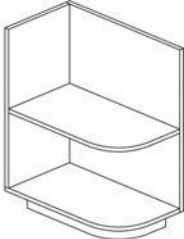
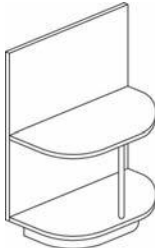
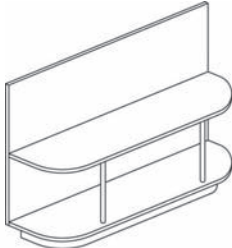
		WIDTHS	HEIGHTS	DEPTHS	DESCRIPTION
B7021 TOTE TRAY BASE		36			TWO HINGED DOORS NOMINAL TOTE SIZES 36"- (15) 9.5" WIDE TOTE TRAYS 39"- (15) 9.5" WIDE TOTE TRAYS 42"- (15) 9.5" WIDE TOTE TRAYS 45"- (15) 12.5" WIDE TOTE TRAYS 48"- (15) 13.5" WIDE TOTE TRAYS ORDER TOTES SEPARATELY
		39	29	23.25	
		42	32		
		45	34.5		
		48			
B7022 TOTE TRAY BASE		39	25.75	23.25	TWO HINGED DOORS NOMINAL TOTE SIZES 39"- (16) 7.5" WIDE TOTE TRAYS 42"- (16) 7.5" WIDE TOTE TRAYS 45"- (16) 7.5" WIDE TOTE TRAYS 48"- (16) 9.5" WIDE TOTE TRAYS ORDER TOTES SEPARATELY
		42	29		
		45	32		
		48	34.5		
B7023 TOTE TRAY BASE		36		23.25	TWO HINGED DOORS NOMINAL TOTE SIZES 36"- (18) 9.5" WIDE TOTE TRAYS 39"- (18) 9.5" WIDE TOTE TRAYS 42"- (18) 9.5" WIDE TOTE TRAYS 45"- (18) 12.5" WIDE TOTE TRAYS 48"- (18) 13.5" WIDE TOTE TRAYS ORDER TOTES SEPARATELY
		39			
		42	32		
		45	34.5		
		48			
B7024 TOTE TRAY BASE		39	29	23.25	TWO HINGED DOORS NOMINAL TOTE SIZES 39"- (20) 7.5" WIDE TOTE TRAYS 42"- (20) 7.5" WIDE TOTE TRAYS 45"- (20) 7.5" WIDE TOTE TRAYS 48"- (20) 9.5" WIDE TOTE TRAYS ORDER TOTES SEPARATELY
		42	32		
		45	34.5		
		48			

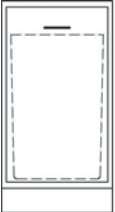

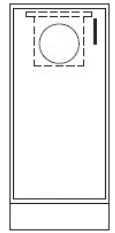
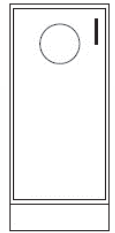

		WIDTHS	HEIGHTS	DEPTHS	DESCRIPTION
B7025 TOTE TRAY BASE		39			TWO HINGED DOORS
		42	32		NOMINAL TOTE SIZES
		45	34.5	23.25	39"- (24) 7.5" WIDE TOTE TRAYS
		48			42"- (24) 7.5" WIDE TOTE TRAYS
					45"- (24) 7.5" WIDE TOTE TRAYS
				48"- (24) 9.5" WIDE TOTE TRAYS	
					ORDER TOTES SEPARATELY

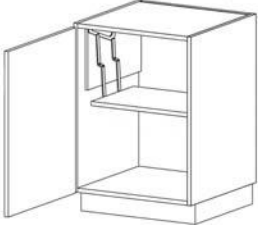
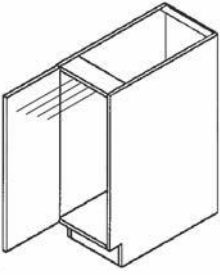

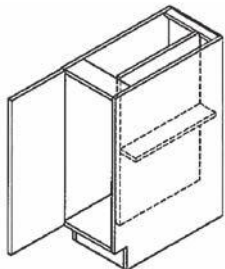
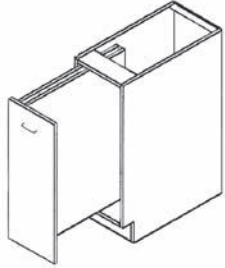
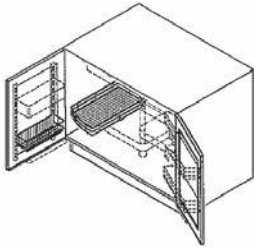
		WIDTHS	HEIGHTS	DEPTHS	DESCRIPTION
B1014		13.25	29 32 34.5	23.25	DECORATIVE END-CAP UNIT 8" RADIUSED BOTTOM AND SHELF
B1015		13.25	29 32 34.5	23.25	DECORATIVE END-CAP UNIT 8" RADIUSED BOTTOM AND SHELF
B1016		13.25	29 32 34.5	13.25	DECORATIVE END-CAP UNIT 8" RADIUSED BOTTOM AND SHELF
B1017		46.5	29 32 34.5	13.25	DECORATIVE END-CAP UNIT 8" RADIUSED BOTTOM AND SHELF

		WIDTHS	HEIGHTS	DEPTHS	DESCRIPTION
<p>B2030</p> <p>TILT-OUT WASTE BASE</p> 	<p>15 18 21 24</p>	<p>29 32 34.5</p>	<p>23.25</p>	<p>BOTTOM HINGED DOOR DOOR MOUNTED WASTE HOLDS ONE #2957 WASTE BIN</p>	
<p>B2031</p> <p>SLIDE-OUT WASTE BASE</p> 	<p>15 18 21 24</p>	<p>29 32 34.5</p>	<p>23.25</p>	<p>SLIDE OUT DOOR DOOR MOUNTED WASTE HOLDS ONE #2957 WASTE BIN</p>	
<p>B2035 HINGED LEFT</p> <p>B2036 HINGED RIGHT</p> <p>FLIPPER DOOR WASTE BASE</p> 	<p>15 18 21 24</p>	<p>34.5</p>	<p>23.25</p>	<p>HINGED DOOR WITH GROMMET FLIPPER DOOR BEHIND HOLDS ONE #2957 WASTE BIN</p>	
<p>B2037 HINGED LEFT</p> <p>B2038 HINGED RIGHT</p> <p>GROMMET WASTE BASE</p> 	<p>15 18 21 24</p>	<p>34.5</p>	<p>23.25</p>	<p>HINGED DOOR WITH GROMMET HOLDS ONE #2957 WASTE BIN</p>	



		WIDTHS	HEIGHTS	DEPTHS	DESCRIPTION
<p>B2039 HINGED LEFT</p> <p>B2040 HINGED RIGHT</p> <p>OPEN WASTE BASE</p>		<p>15 18 21 24</p>	<p>34.5</p>	<p>23.25</p>	<p>HINGED DOOR OPEN AREA ABOVE HOLDS ONE #2957 WASTE BIN</p>
<p>B2063 HINGED LEFT</p> <p>B2064 HINGED RIGHT</p> <p>SEWING MACHINE BASE</p>		<p>24</p>	<p>32 34.5</p>	<p>23.25</p>	<p>HINGED DOOR PULLOUT SEWING ASSEMBLY VERIFY SEWING MACHINE REQ'D SEWING MACHINE NOT INCLUDED</p>
<p>B2059 HINGED LEFT</p> <p>B2060 HINGED RIGHT</p> <p>STAND MIXER BASE</p>		<p>18 21</p>	<p>*32 34.5</p>	<p>23.25</p>	<p>HINGED DOOR SLIDING TRAY AT BOTTOM SWING-UP SEWING ASSEMBLY VERIFY STAND MIXER REQ'D STAND MIXER NOT INCLUDED *32" WILL NOT INCLUDE SLIDING TRAY</p>
<p>B2081 HINGED LEFT</p> <p>B2082 HINGED RIGHT</p> <p>TOWEL STORAGE BASE</p>		<p>9</p>	<p>32 34.5</p>	<p>23.25</p>	<p>HINGED DOOR ONE PULLOUT TOWEL DRYING RACK STORAGE FOR DETERGENTS, ETC</p>

		WIDTHS	HEIGHTS	DEPTHS	DESCRIPTION
<p>B2083 HINGED LEFT</p> <p>B2084 HINGED RIGHT</p> <p>TRAY STORAGE BASE</p>		<p>9 12 15</p>	<p>32 34.5</p>	<p>23.25</p>	<p>HINGED DOOR ONE TRAY PARTITION CENTERED ONE FIXED SHELF ON RIGHT</p>
<p>B2085</p> <p>SLIDING UTENSIL STORAGE BASE</p>		<p>9 12</p>	<p>32 34.5</p>	<p>23.25</p>	<p>HINGED DOOR ON PULLOUT UTENSIL ASSEMBLY SPECIFY ASSEMBLY ON RIGHT OR LEFT</p>
<p>B2086</p> <p>PANTRY STORAGE BASE</p>		<p>36</p>	<p>32 34.5</p>	<p>23.25</p>	<p>HINGED DOORS ADJUSTABLE WIRE DOOR RACKS SHALLOW DEPTH SHELVING AT REAR SWING-OUT WIRE BASKETS</p>

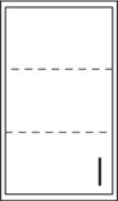
		WIDTHS	HEIGHTS	DEPTHS	DESCRIPTION
W0000 WALL CABINET MOD- IFIER		SPECIFY	SPECIFY	SPECIFY	
W1001 OPEN WALL		12 15 18 21 24 27 30 33 36 39 42 45 48	12 15 16 19 24 25 31 32 36 42 48	13.25 15.25	
W1002 OPEN WALL		12 15 18 21 24 27 30 33 36 39 42 45 48	15 16 19 24 25 31 32 36 42 48	13.25 15.25	ONE ADJUSTABLE SHELF
W1003 OPEN WALL		12 15 18 21 24 27 30 33 36 39 42 45 48	19 24 25 31 32 36 42 48	13.25 15.25	TWO ADJUSTABLE SHELVES

		WIDTHS	HEIGHTS	DEPTHS	DESCRIPTION			
W1004 OPEN WALL		12			THREE ADJUSTABLE SHELVES			
		15						
		18						
		21						
		24	31					
		27	32	13.25				
		30	36	15.25				
		33	42					
		36	48					
		39						
		42						
		45						
		48						
W2001 HINGED LEFT W2002 HINGED RIGHT DOOR WALL		12	12		HINGED DOOR			
		15	15					
		18	16					
		21	19					
		24	24	13.25				
			25	15.25				
			31					
			32					
			36					
			42					
			48					
		W2003 HINGED LEFT W2004 HINGED RIGHT DOOR WALL		12		15		HINGED DOOR ONE ADJUSTABLE SHELF
				15		16		
18	19							
21	24			13.25				
24	25			15.25				
	31							
	32							
	36							
	42							
	48							
W2005 HINGED LEFT W2006 HINGED RIGHT DOOR WALL				12	24		HINGED DOOR TWO ADJUSTABLE SHELF	
				15	25			
				18	31	13.25		
		21	32	15.25				
		24	36					
			42					
			48					

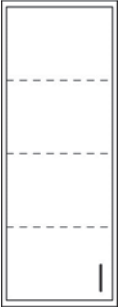
DOOR CABINETS

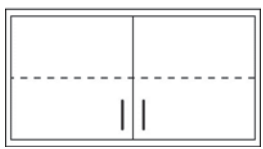
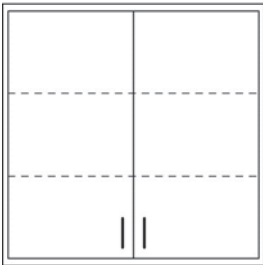
		WIDTHS	HEIGHTS	DEPTHS	DESCRIPTION
W2007 HINGED LEFT W2008 HINGED RIGHT DOOR WALL		12	31	13.25 15.25	HINGED DOOR THREE ADJUSTABLE SHELVES
		15 18 21 24	32 36 42 48		
W2009 DOOR WALL		24 27 30 33 36 39 42 45 48	12 15 16 19 24 25 31 32 36 42 48	13.25 15.25	TWO HINGED DOORS
W2010 DOOR WALL		24 27 30 33 36 39 42 45 48	15 16 19 24 25 31 32 36 42 48	13.25 15.25	TWO HINGED DOORS ONE ADJUSTABLE SHELF
W2011 DOOR WALL		24 27 30 33 36 39 42 45 48	24 25 31 32 36 42 48	13.25 15.25	TWO HINGED DOORS TWO ADJUSTABLE SHELVES

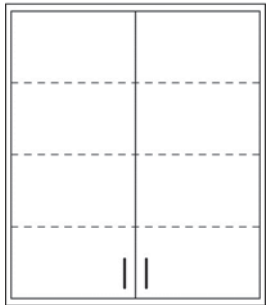
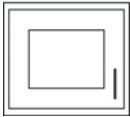
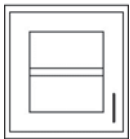
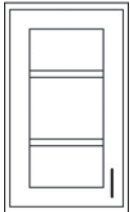
		WIDTHS	HEIGHTS	DEPTHS	DESCRIPTION
W2012 DOOR WALL		24			TWO HINGED DOORS THREE ADJUSTABLE SHELVES
		27			
		30	31	13.25	
		33	32	15.25	
		36	36		
		39	42		
		42	48		
		45			
48					
W2101 HINGED LEFT W2102 HINGED RIGHT FRAMED GLASS DOOR WALL		12	15		HINGED DOOR FRAMED GLASS DOOR
		15	16		
		18	19	13.25	
		21	24	15.25	
		24	25		
			31		
			32		
			36		
	42				
	48				
W2103 HINGED LEFT W2104 HINGED RIGHT FRAMED GLASS DOOR WALL		12	15		HINGED DOOR FRAMED GLASS DOOR ONE ADJUSTABLE SHELF
		15	16		
		18	19	13.25	
		21	24	15.25	
		24	25		
			31		
			32		
			36		
	42				
	48				
W2105 HINGED LEFT W2106 HINGED RIGHT FRAMED GLASS DOOR WALL		12	24		HINGED DOOR FRAMED GLASS DOOR ONE ADJUSTABLE SHELF
		15	25		
		18	31	13.25	
		21	32	15.25	
		24	36		
			42		
			48		

DOOR CABINETS

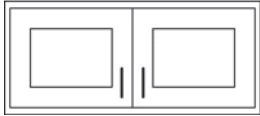
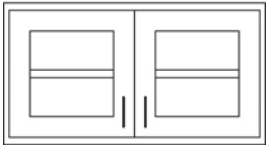
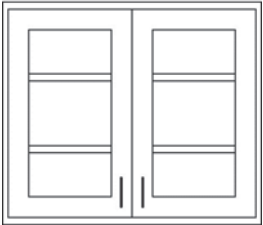
		WIDTHS	HEIGHTS	DEPTHS	DESCRIPTION
<p>W2107 HINGED LEFT</p> <p>W2108 HINGED RIGHT</p> <p>FRAMED GLASS DOOR WALL</p>		<p>12 15 18 21 24</p>	<p>31 32 36 42 48</p>	<p>13.25 15.25</p>	<p>HINGED DOOR FRAMED GLASS DOOR THREE ADJUSTABLE SHELVES</p>
<p>W2109</p> <p>FRAMED GLASS DOOR WALL</p>		<p>24 27 30 33 36 39 42 45 48</p>	<p>15 16 19 24 31 32 36 42 48</p>	<p>13.25 15.25</p>	<p>HINGED DOORS FRAMED GLASS DOORS</p>
<p>W2110</p> <p>FRAMED GLASS DOOR WALL</p>		<p>24 27 30 33 36 39 42 45 48</p>	<p>15 16 19 24 31 32 36 42 48</p>	<p>13.25 15.25</p>	<p>HINGED DOORS FRAMED GLASS DOORS ONE ADJUSTABLE SHELF</p>
<p>W2111</p> <p>FRAMED GLASS DOOR WALL</p>		<p>24 27 30 33 36 39 42 45 48</p>	<p>15 16 19 24 31 32 36 42 48</p>	<p>13.25 15.25</p>	<p>HINGED DOORS FRAMED GLASS DOORS TWO ADJUSTABLE SHELVES</p>

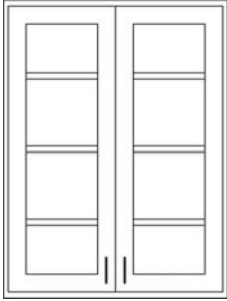
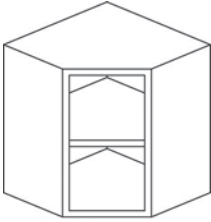
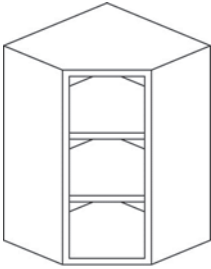
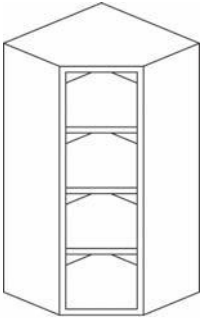
		WIDTHS	HEIGHTS	DEPTHS	DESCRIPTION
W2112 DOOR WALL		24			HINGED DOORS FRAMED GLASS DOORS THREE ADJUSTABLE SHELVES
		27			
		30	31	13.25	
		33	32	15.25	
		36	36		
		39	42		
		42	48		
		45 48			
W6001 CORNER OPEN WALL		23.25	19		ONE ADJUSTABLE SHELF (13.25" REQUIRES 23.25" WALL SPACE) (15.25" REQUIRES 25.25" WALL SPACE)
		25.25	24		
			31	13.25	
			32	15.25	
			36		
			42 48		
W6002 CORNER OPEN WALL		23.25	31		TWO ADJUSTABLE SHELVES (13.25" REQUIRES 23.25" WALL SPACE) (15.25" REQUIRES 25.25" WALL SPACE)
		25.25	32	13.25	
			36	15.25	
			42		
			48		
W6003 CORNER OPEN WALL		23.25	36		THREE ADJUSTABLE SHELVES (13.25" REQUIRES 23.25" WALL SPACE) (15.25" REQUIRES 25.25" WALL SPACE)
		25.25	42	13.25	
			48	15.25	

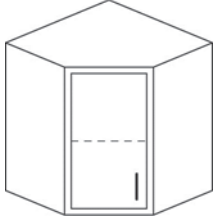
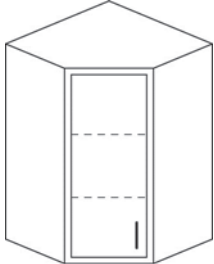
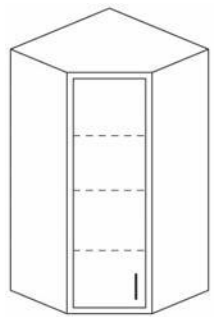
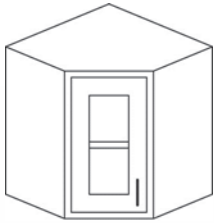

CORNER WALL CABINETS

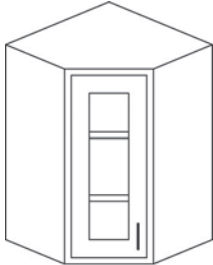
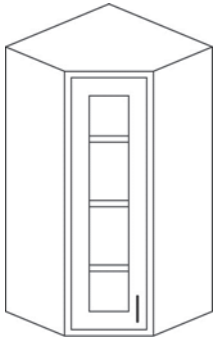
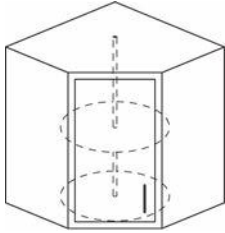
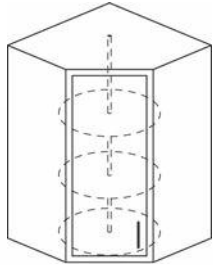
		WIDTHS	HEIGHTS	DEPTHS	DESCRIPTION
W6004 HINGED RIGHT W6005 HINGED LEFT CORNER DOOR WALL		23.25 25.25	19 24 31 32 36 42 48	13.25 15.25	HINGED DOOR ONE ADJUSTABLE SHELF REQUIRES 1.75" FILLER BETWEEN ADJOINING CABINETRY (13.25" REQUIRES 23.25" WALL SPACE) (15.25" REQUIRES 25.25" WALL SPACE)
W6006 HINGED RIGHT W6007 HINGED LEFT CORNER DOOR WALL		23.25 25.25	31 32 36 42 48	13.25 15.25	HINGED DOOR TWO ADJUSTABLE SHELVES REQUIRES 1.75" FILLER BETWEEN ADJOINING CABINETRY (13.25" REQUIRES 23.25" WALL SPACE) (15.25" REQUIRES 25.25" WALL SPACE)
W6008 HINGED RIGHT W6009 HINGED LEFT CORNER DOOR WALL		23.25 25.25	36 42 48	13.25 15.25	HINGED DOOR THREE ADJUSTABLE SHELVES REQUIRES 1.75" FILLER BETWEEN ADJOINING CABINETRY (13.25" REQUIRES 23.25" WALL SPACE) (15.25" REQUIRES 25.25" WALL SPACE)
W6102 HINGED RIGHT W6101 HINGED LEFT CORNER DOOR WALL		23.25 25.25	19 24 31 32 36 42 48	13.25 15.25	HINGED FRAMED GLASS DOOR ONE ADJUSTABLE SHELF REQUIRES 1.75" FILLER BETWEEN ADJOINING CABINETRY (13.25" REQUIRES 23.25" WALL SPACE) (15.25" REQUIRES 25.25" WALL SPACE)

		WIDTHS	HEIGHTS	DEPTHS	DESCRIPTION
<p>W6104 HINGED RIGHT</p> <p>W6103 HINGED LEFT</p> <p>CORNER DOOR WALL</p>		<p>23.25 25.25</p>	<p>31 32 36 42 48</p>	<p>13.25 15.25</p>	<p>HINGED FRAMED GLASS DOOR TWO ADJUSTABLE SHELVES REQUIRES 1.75" FILLER BETWEEN AD- JOINING CABINERY (13.25" REQUIRES 23.25" WALL SPACE) (15.25" REQUIRES 25.25" WALL SPACE)</p>
<p>W6106 HINGED RIGHT</p> <p>W6105 HINGED LEFT</p> <p>CORNER DOOR WALL</p>		<p>23.25 25.25</p>	<p>36 42 48</p>	<p>13.25 15.25</p>	<p>HINGED FRAMED GLASS DOOR THREE ADJUSTABLE SHELVES REQUIRES 1.75" FILLER BETWEEN AD- JOINING CABINERY (13.25" REQUIRES 23.25" WALL SPACE) (15.25" REQUIRES 25.25" WALL SPACE)</p>
<p>W6010 HINGED RIGHT</p> <p>W6011 HINGED LEFT</p> <p>CORNER CAROUSEL WALL</p>		<p>23.25 25.25</p>	<p>24 31 32 36 42 48</p>	<p>13.25 15.25</p>	<p>HINGED DOOR TWO REVOLVING ADJUSTABLE SHELF REQUIRES 1.75" FILLER BETWEEN AD- JOINING CABINERY (13.25" REQUIRES 23.25" WALL SPACE) (15.25" REQUIRES 25.25" WALL SPACE)</p>
<p>W6012 HINGED RIGHT</p> <p>W6013 HINGED LEFT</p> <p>CORNER CAROUSEL WALL</p>		<p>23.25 25.25</p>	<p>31 32 36 42 48</p>	<p>13.25 15.25</p>	<p>HINGED DOOR THREE REVOLVING ADJ SHELVES REQUIRES 1.75" FILLER BETWEEN AD- JOINING CABINERY (13.25" REQUIRES 23.25" WALL SPACE) (15.25" REQUIRES 25.25" WALL SPACE)</p>

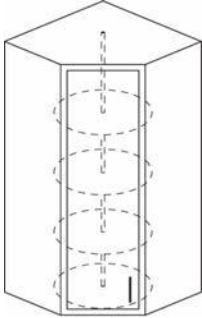
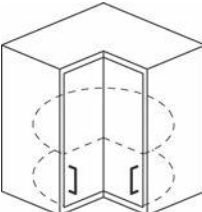
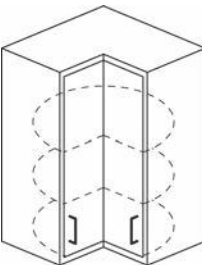
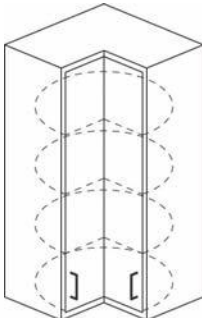
CORNER WALL CABINETS

		WIDTHS	HEIGHTS	DEPTHS	DESCRIPTION
<p>W6014 HINGED RIGHT</p> <p>W6015 HINGED LEFT</p> <p>CORNER CAROUSEL WALL</p>		<p>23.25 25.25</p>	<p>42 48</p>	<p>13.25 15.25</p>	<p>HINGED DOOR FOUR REVOLVING ADJ SHELVES REQUIRES 1.75" FILLER BETWEEN AD- JOINING CABINETS (13.25" REQUIRES 23.25" WALL SPACE) (15.25" REQUIRES 25.25" WALL SPACE)</p>
<p>W6016</p> <p>CORNER CAROUSEL WALL</p>		<p>23.25 25.25</p>	<p>24 31 32 36 42 48</p>	<p>13.25 15.25</p>	<p>REVOLVING DOORS TWO REVOLVING ADJ SHELVES (13.25" REQUIRES 23.25" WALL SPACE) (15.25" REQUIRES 25.25" WALL SPACE)</p>
<p>W6017</p> <p>CORNER CAROUSEL WALL</p>		<p>23.25 25.25</p>	<p>31 32 36 42 48</p>	<p>13.25 15.25</p>	<p>REVOLVING DOORS THREE REVOLVING ADJ SHELVES (13.25" REQUIRES 23.25" WALL SPACE) (15.25" REQUIRES 25.25" WALL SPACE)</p>
<p>W6018</p> <p>CORNER CAROUSEL WALL</p>		<p>23.25 25.25</p>	<p>31 32 36 42 48</p>	<p>13.25 15.25</p>	<p>REVOLVING DOORS FOUR REVOLVING ADJ SHELVES (13.25" REQUIRES 23.25" WALL SPACE) (15.25" REQUIRES 25.25" WALL SPACE)</p>

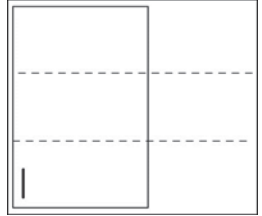
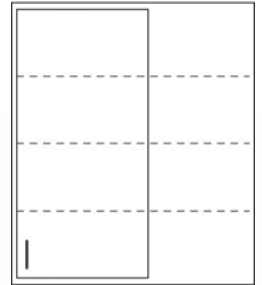
		WIDTHS	HEIGHTS	DEPTHS	DESCRIPTION
W6019 PANEL LEFT W6020 PANEL RIGHT DEAD CORNER WALL		30 33 36 39	15 19 24 31 32 36 42 48	13.25 15.25	HINGED DOOR HINGES TO FULL FINISHED PANEL
W6021 PANEL LEFT W6022 PANEL RIGHT DEAD CORNER WALL		30 33 36 39	19 24 31 32 36 42 48	13.25 15.25	HINGED DOOR HINGES TO FULL FINISHED PANEL ONE ADJUSTABLE SHELF
W6023 PANEL LEFT W6024 PANEL RIGHT DEAD CORNER WALL		30 33 36 39	31 32 36 42 48	13.25 15.25	HINGED DOOR HINGES TO FULL FINISHED PANEL TWO ADJUSTABLE SHELVES
W6025 PANEL LEFT W6026 PANEL RIGHT DEAD CORNER WALL		30 33 36 39	36 42 48	13.25 15.25	HINGED DOOR HINGES TO FULL FINISHED PANEL THREE ADJUSTABLE SHELVES

CORNER WALL CABINETS

		WIDTHS	HEIGHTS	DEPTHS	DESCRIPTION
W6107 PANEL LEFT W6108 PANEL RIGHT DEAD CORNER WALL		30 33 36 39	15 19 24 31 32 36 42 48	13.25 15.25	HINGED FRAMED GLASS DOOR HINGES TO FULL FINISHED PANEL
W6109 PANEL LEFT W6110 PANEL RIGHT DEAD CORNER WALL		30 33 36 39	19 24 31 32 36 42 48	13.25 15.25	HINGED FRAMED GLASS DOOR HINGES TO FULL FINISHED PANEL ONE ADJUSTABLE SHELF
W6111 PANEL LEFT W6112 PANEL RIGHT DEAD CORNER WALL		30 33 36 39	31 32 36 42 48	13.25 15.25	HINGED FRAMED GLASS DOOR HINGES TO FULL FINISHED PANEL TWO ADJUSTABLE SHELVES
W6113 PANEL LEFT W6114 PANEL RIGHT DEAD CORNER WALL		30 33 36 39	36 42 48	13.25 15.25	HINGED FRAMED GLASS DOOR HINGES TO FULL FINISHED PANEL THREE ADJUSTABLE SHELVES

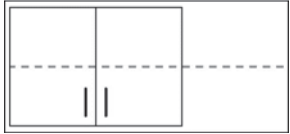
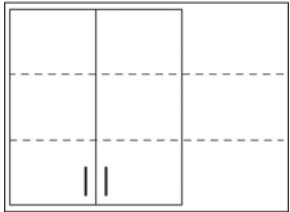
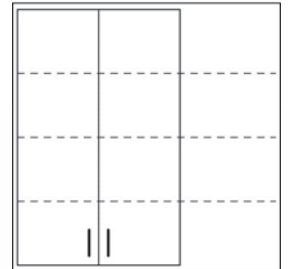

		WIDTHS	HEIGHTS	DEPTHS	DESCRIPTION
W6027 PANEL LEFT W6028 PANEL RIGHT DEAD CORNER WALL		39 42 45 48	19 19 24 31 32 36 42 48	13.25 15.25	HINGED DOORS
W6029 PANEL LEFT W6030 PANEL RIGHT DEAD CORNER WALL		39 42 45 48	19 24 31 32 36 42 48	13.25 15.25	HINGED DOORS ONE ADJUSTABLE SHELF
W6031 PANEL LEFT W6032 PANEL RIGHT DEAD CORNER WALL		39 42 45 48	31 32 36 42 48	13.25 15.25	HINGED DOORS TWO ADJUSTABLE SHELVES
W6033 PANEL LEFT W6034 PANEL RIGHT DEAD CORNER WALL		39 42 45 48	36 42 48	13.25 15.25	HINGED DOORS THREE ADJUSTABLE SHELVES

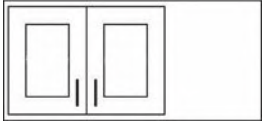
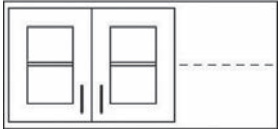
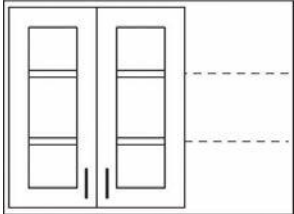
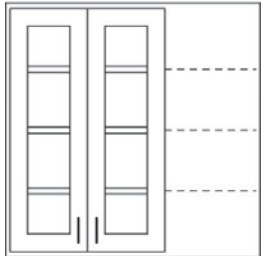
CORNER WALL CABINETS

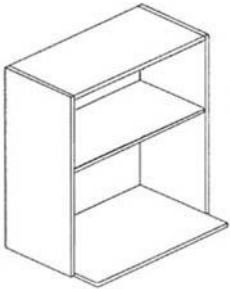
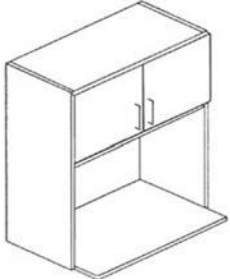
		WIDTHS	HEIGHTS	DEPTHS	DESCRIPTION
<p>W6115 PANEL LEFT</p> <p>W6116 PANEL RIGHT</p> <p>DEAD CORNER WALL</p>		<p>39</p> <p>42</p> <p>45</p> <p>48</p>	<p>15</p> <p>19</p> <p>24</p> <p>31</p> <p>32</p> <p>36</p> <p>42</p> <p>48</p>	<p>13.25</p> <p>15.25</p>	<p>HINGED FRAMED GLASS DOORS</p>
<p>W6117 PANEL LEFT</p> <p>W6118 PANEL RIGHT</p> <p>DEAD CORNER WALL</p>		<p>39</p> <p>42</p> <p>45</p> <p>48</p>	<p>19</p> <p>24</p> <p>31</p> <p>32</p> <p>36</p> <p>42</p> <p>48</p>	<p>13.25</p> <p>15.25</p>	<p>HINGED FRAMED GLASS DOORS ONE ADJUSTABLE SHELF</p>
<p>W6119 PANEL LEFT</p> <p>W6120 PANEL RIGHT</p> <p>DEAD CORNER WALL</p>		<p>39</p> <p>42</p> <p>45</p> <p>48</p>	<p>31</p> <p>32</p> <p>36</p> <p>42</p> <p>48</p>	<p>13.25</p> <p>15.25</p>	<p>HINGED FRAMED GLASS DOORS TWO ADJUSTABLE SHELVES</p>
<p>W6121 PANEL LEFT</p> <p>W6122 PANEL RIGHT</p> <p>DEAD CORNER WALL</p>		<p>39</p> <p>42</p> <p>45</p> <p>48</p>	<p>36</p> <p>42</p> <p>48</p>	<p>13.25</p> <p>15.25</p>	<p>HINGED FRAMED GLASS DOORS THREE ADJUSTABLE SHELVES</p>

		WIDTHS	HEIGHTS	DEPTHS	DESCRIPTION
<p>W3001 OPEN MICROWAVE WALL</p>		<p>27 30 33 36</p>	<p>31</p>	<p>13.25 15.25</p>	<p>FIXED CENTER SHELF FINISHED INTERIOR 17" DEEP BOTTOM SHELF SUFFIX -R FOR RADIUSED SHELF</p>
<p>W3002 DOOR MICROWAVE WALL</p>		<p>27 30 33 36</p>	<p>31</p>	<p>13.25 15.25</p>	<p>HINGED DOORS FIXED CENTER SHELF FINISHED INTERIOR 17" DEEP BOTTOM SHELF SUFFIX -R FOR RADIUSED SHELF</p>

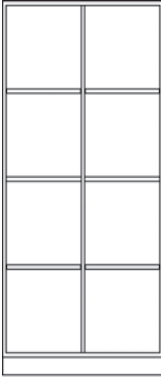

OPEN TALL CABINETS

		WIDTHS	HEIGHTS	DEPTHS	DESCRIPTION
T0000 TALL CABINET MOD- IFIER		SPECIFY	SPECIFY	SPECIFY	
T1001 OPEN STORAGE TALL		12 15 18 21 24 27 30 33 36 39 42 45 48	48 54 60 66 72 78 84	13.25 15.25 23.25 28.25	ONE FIXED CENTER SHELF TWO ADJUSTABLE SHELVES
T1002 OPEN STORAGE TALL		12 15 18 21 24 27 30 33 36 39 42 45 48	48 54 60 66 72 78 84	13.25 15.25 23.25 28.25	ONE FIXED CENTER SHELF FOUR ADJUSTABLE SHELVES

		WIDTHS	HEIGHTS	DEPTHS	DESCRIPTION
T1003 OPEN STORAGE TALL		12	48	13.25 15.25 23.25 28.25	ONE VERTICAL PARTITION TWO FIXED CENTER SHELVES FOUR ADJUSTABLE SHELVES
		15			
		18			
		21			
		24			
		27			
		30			
		33			
		36			
		39			
		42			
		45			
		48			
		T1004 OPEN STORAGE TALL			
15					
18					
21					
24					
27					
30					
33					
36					
39					
42					
45					
48					

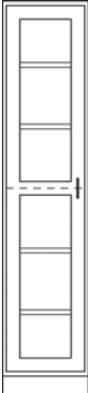
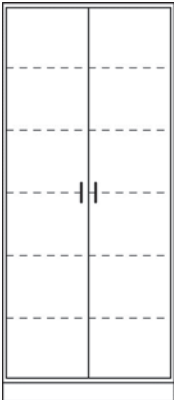
DOOR TALL CABINETS

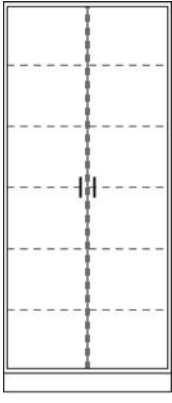
		WIDTHS	HEIGHTS	DEPTHS	DESCRIPTION
<p>T2001 HINGED LEFT</p> <p>T2002 HINGED RIGHT</p> <p>DOOR GENERAL STORAGE TALL</p>		<p>12</p> <p>15</p> <p>18</p> <p>21</p> <p>24</p>	<p>84</p>	<p>15.25</p> <p>23.25</p> <p>28.25</p>	<p>HINGED DOOR</p> <p>ONE FIXED CENTER SHELF</p> <p>FOUR ADJUSTABLE SHELVES</p>
<p>T2101 HINGED LEFT</p> <p>T2102 HINGED RIGHT</p> <p>FRAMED GLASS DOOR GENERAL STORAGE TALL</p>		<p>12</p> <p>15</p> <p>18</p> <p>21</p> <p>24</p>	<p>84</p>	<p>15.25</p> <p>23.25</p> <p>28.25</p>	<p>HINGED DOOR</p> <p>FRAMED GLASS DOOR</p> <p>ONE FIXED CENTER SHELF</p> <p>FOUR ADJUSTABLE SHELVES</p>
<p>T2003</p> <p>DOOR GENERAL STORAGE TALL</p>		<p>24</p> <p>27</p> <p>30</p> <p>33</p> <p>36</p> <p>39</p> <p>42</p> <p>45</p> <p>48</p>	<p>84</p>	<p>15.25</p> <p>23.25</p> <p>28.25</p>	<p>HINGED DOORS</p> <p>ONE FIXED CENTER SHELF</p> <p>FOUR ADJUSTABLE SHELVES</p>

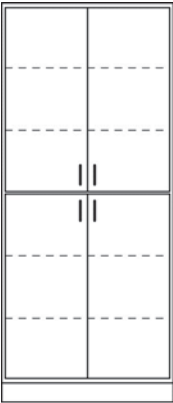
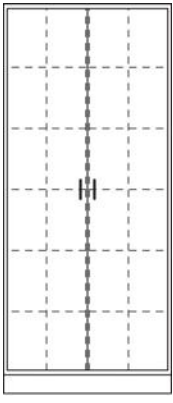

		WIDTHS	HEIGHTS	DEPTHS	DESCRIPTION
T2103 FRAMED GLASS DOOR GENERAL STORAGE TALL		24	84	15.25 23.25 28.25	HINGED DOORS FRAMED GLASS DOORS ONE FIXED CENTER SHELF FOUR ADJUSTABLE SHELVES
		27			
		30			
		33			
		36			
		39			
		42			
45					
48					
T2004 DOOR GENERAL STORAGE TALL		24	84	15.25 23.25 28.25	HINGED DOORS ONE CENTER PARTITION TWO FIXED CENTER SHELVES EIGHT ADJUSTABLE SHELVES
		27			
		30			
		33			
		36			
		39			
		42			
45					
48					
T2005 HINGED LEFT T2006 HINGED RIGHT SPLIT DOOR GENERAL STORAGE TALL		12	84	15.25 23.25 28.25	HINGED DOORS FIXED CENTER FLOOR FOUR ADJUSTABLE SHELVES
		15			
		18			
		21			
		24			

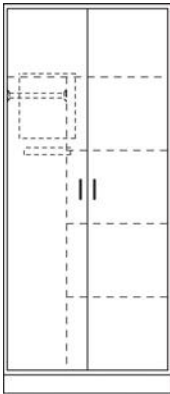
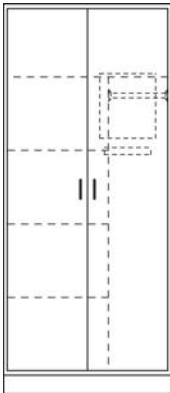

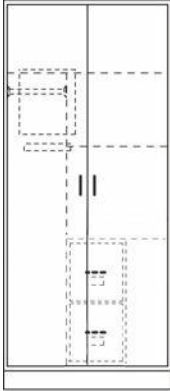
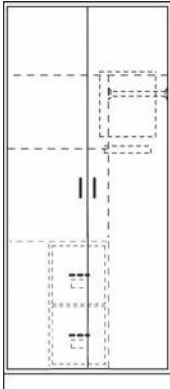
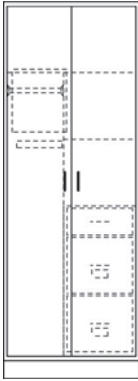
		WIDTHS	HEIGHTS	DEPTHS	DESCRIPTION
<p>T2007</p> <p>SPLIT DOOR GENERAL STORAGE TALL</p>		<p>24 27 30 33 36 39 42 45 48</p>	<p>84</p>	<p>15.25 23.25 28.25</p>	<p>HINGED DOORS FIXED CENTER FLOOR FOUR ADJUSTABLE SHELVES</p>
<p>T2008</p> <p>DOOR FLEXIBLE STORAGE TALL</p>		<p>24 27 30 33 36 39 42 45 48</p>	<p>84</p>	<p>15.25 23.25 28.25</p>	<p>HINGED DOORS THREE VERTICAL PARTITIONS FOUR FIXED CENTER SHELVES SIXTEEN ADJUSTABLE SHELVES</p>

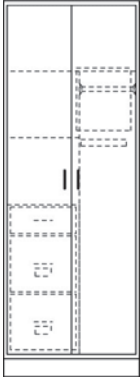
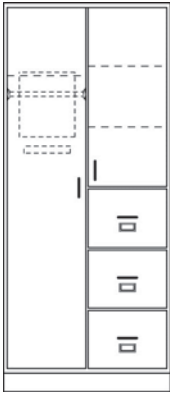
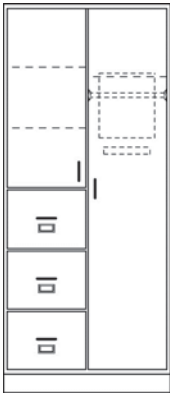
		WIDTHS	HEIGHTS	DEPTHS	DESCRIPTION
<p>T3001 HINGED LEFT</p> <p>T3002 HINGED RIGHT</p> <p>TEACHER WARDROBE TALL</p>		<p>12 15 18 21 24</p>	<p>84</p>	<p>23.25</p>	<p>HINGED DOOR FIXED SHELF CHROME HANGER ROD MIRROR AND PIN TRAY</p>
<p>T3003</p> <p>TEACHER WARDROBE TALL</p>		<p>24 27 30 33 36 39 42 45 48</p>	<p>84</p>	<p>23.25</p>	<p>HINGED DOORS TWO FIXED SHELVES CHROME HANGER ROD MIRROR AND PIN TRAY TWO ADJUSTABLE SHELVES</p>
<p>T3004</p> <p>TEACHER WARDROBE TALL</p>		<p>24 27 30 33 36 39 42 45 48</p>	<p>84</p>	<p>23.25</p>	<p>HINGED DOORS TWO FIXED SHELVES CHROME HANGER ROD MIRROR AND PIN TRAY TWO ADJUSTABLE SHELVES</p>

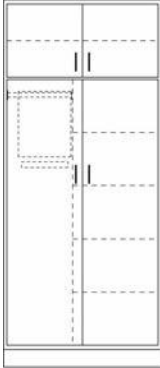
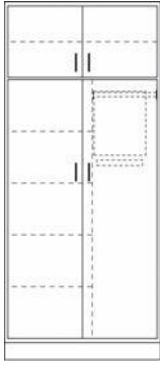
		WIDTHS	HEIGHTS	DEPTHS	DESCRIPTION
<p>T3005</p> <p>TEACHER WARDROBE TALL</p> 	<p>30</p> <p>33</p> <p>36</p> <p>39</p> <p>42</p> <p>45</p> <p>48</p>	84	23.25	<p>HINGED DOORS</p> <p>TWO FIXED SHELVES</p> <p>CHROME HANGER ROD</p> <p>MIRROR AND PIN TRAY</p> <p>TWO LETTER FILE DRAWERS</p> <p>CARD HOLDERS</p> <p>FILE RAILS</p> <p>ADJUSTABLE SHELF</p>	
<p>T3006</p> <p>TEACHER WARDROBE TALL</p> 	<p>30</p> <p>33</p> <p>36</p> <p>39</p> <p>42</p> <p>45</p> <p>48</p>	84	23.25	<p>HINGED DOORS</p> <p>TWO FIXED SHELVES</p> <p>CHROME HANGER ROD</p> <p>MIRROR AND PIN TRAY</p> <p>TWO LETTER FILE DRAWERS</p> <p>CARD HOLDERS</p> <p>FILE RAILS</p> <p>ADJUSTABLE SHELF</p>	
<p>T3007</p> <p>TEACHER WARDROBE TALL</p> 	<p>30</p> <p>33</p> <p>36</p> <p>39</p> <p>42</p> <p>45</p> <p>48</p>	84	23.25	<p>HINGED DOORS</p> <p>TWO FIXED SHELVES</p> <p>CHROME HANGER ROD</p> <p>MIRROR AND PIN TRAY</p> <p>STANDARD DRAWER</p> <p>TWO LETTER FILE DRAWERS</p> <p>CARD HOLDERS</p> <p>FILE RAILS</p> <p>ADJUSTABLE SHELF</p>	

		WIDTHS	HEIGHTS	DEPTHS	DESCRIPTION
T3008 TEACHER WARDROBE TALL		30	84	23.25	HINGED DOORS TWO FIXED SHELVES CHROME HANGER ROD MIRROR AND PIN TRAY STANDARD DRAWER TWO LETTER FILE DRAWERS CARD HOLDERS FILE RAILS ADJUSTABLE SHELF
		33			
36					
39					
42					
45					
48					
T3009 TEACHER WARDROBE TALL		36	84	23.25	HINGED DOORS TWO FIXED SHELVES CHROME HANGER ROD MIRROR AND PIN TRAY THREE FILE DRAWERS CARD HOLDERS FILE RAILS TWO ADJUSTABLE SHELVES
		39			
42					
45					
48					
T3010 TEACHER WARDROBE TALL		36			
		39			
42					
45					
48					

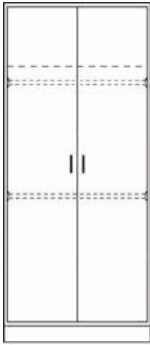

		WIDTHS	HEIGHTS	DEPTHS	DESCRIPTION
<p>T3011</p> <p>TEACHER WARDROBE TALL</p> 		<p>30 33 36 39 42 45 48</p>	84	23.25	<p>HINGED DOORS FIXED FLOOR FIXED SHELF CHROME HANGER ROD MIRROR AND PIN TRAY FOUR ADJUSTABLE SHELVES</p>
<p>T3012</p> <p>TEACHER WARDROBE TALL</p> 		<p>30 33 36 39 42 45 48</p>	84	23.25	<p>HINGED DOORS FIXED FLOOR FIXED SHELF CHROME HANGER ROD MIRROR AND PIN TRAY FOUR ADJUSTABLE SHELVES</p>
<p>T3013 HINGED LEFT</p> <p>T3014 HINGED RIGHT</p> <p>TEACHER WARDROBE TALL</p> 		<p>12 15 18 21 24</p>	84	23.25	<p>HINGED DOOR FIXED SHELF FIXED CHROME HANGER ROD ADJUSTABLE CHROME HANGER ROD</p>

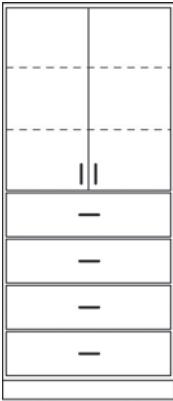
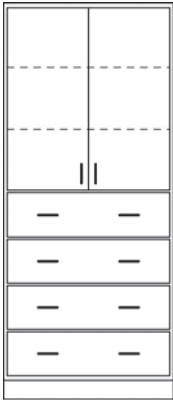

		WIDTHS	HEIGHTS	DEPTHS	DESCRIPTION
<p>T3015</p> <p>TEACHER WARDROBE TALL</p> 		<p>24 27 30 33 36 39 42 45 48</p>	84	23.25	<p>HINGED DOORS FIXED SHELF FIXED CHROME HANGER ROD ADJUSTABLE CHROME HANGER ROD</p>
<p>T3021 HINGED LEFT</p> <p>T3022 HINGED RIGHT</p> <p>TEACHER WARDROBE TALL</p> 		<p>12 15 18 21 24</p>	84	23.25	<p>HINGED DOOR FIXED FLOOR ONE FIXED SHELF CHROME HANGER ROD MIRROR AND PIN TRAY TWO DRAWERS</p>
<p>T3023</p> <p>TEACHER WARDROBE TALL</p> 		<p>24 27 30 33 36 39 42 45 48</p>	84	23.25	<p>HINGED DOORS FIXED FLOOR ONE FIXED SHELF CHROME HANGER ROD MIRROR AND PIN TRAY TWO DRAWERS</p>

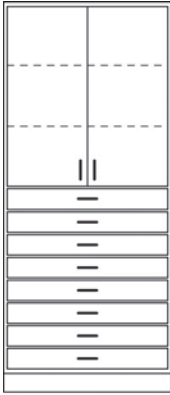

		WIDTHS	HEIGHTS	DEPTHS	DESCRIPTION
T3024 TEACHER WARDROBE TALL		24	84	23.25	HINGED DOORS FIXED FLOOR ONE FIXED SHELF CHROME HANGER ROD MIRROR AND PIN TRAY TWO DRAWERS
		27			
		30			
		33			
		36			
		39			
		42			
45					
		48			

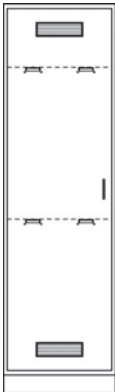

		WIDTHS	HEIGHTS	DEPTHS	DESCRIPTION
<p>T4001 HINGED LEFT</p> <p>T4002 HINGED RIGHT</p> <p>DOOR DRAWER GENERAL STORAGE TALL</p>		<p>12</p> <p>15</p> <p>18</p> <p>21</p> <p>24</p>	<p>84</p>	<p>15.25</p> <p>23.25</p> <p>28.25</p>	<p>HINGED DOOR</p> <p>FIXED CENTER FLOOR</p> <p>TWO ADJUSTABLE SHELVES ABOVE</p> <p>FOUR EQUAL DRAWERS BELOW</p>
<p>T4003</p> <p>DOOR DRAWER GENERAL STORAGE TALL</p>		<p>24</p> <p>27</p> <p>30</p> <p>33</p> <p>36</p> <p>39</p> <p>42</p> <p>45</p> <p>48</p>	<p>84</p>	<p>15.25</p> <p>23.25</p> <p>28.25</p>	<p>HINGED DOORS</p> <p>FIXED CENTER FLOOR</p> <p>TWO ADJUSTABLE SHELVES ABOVE</p> <p>FOUR EQUAL DRAWERS BELOW</p>
<p>T4004</p> <p>DOOR DRAWER GENERAL STORAGE TALL</p>		<p>24</p> <p>27</p> <p>30</p> <p>33</p> <p>36</p> <p>39</p> <p>42</p> <p>45</p> <p>48</p>	<p>84</p>	<p>15.25</p> <p>23.25</p> <p>28.25</p>	<p>HINGED DOORS</p> <p>FIXED CENTER FLOOR</p> <p>TWO ADJUSTABLE SHELVES ABOVE</p> <p>FOUR EQUAL DRAWERS BELOW</p>

COMBINATION TALL CABINETS

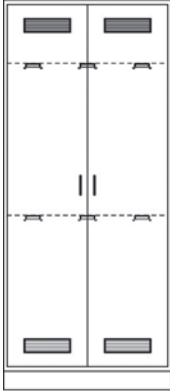
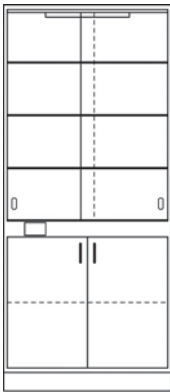

		WIDTHS	HEIGHTS	DEPTHS	DESCRIPTION
<p>T4005</p> <p>DOOR DRAWER GENERAL STORAGE TALL</p>		24	84	15.25 23.25 28.25	<p>HINGED DOORS FIXED CENTER FLOOR TWO ADJUSTABLE SHELVES ABOVE EIGHT EQUAL DRAWERS BELOW</p>
		27			
30					
33					
36					
39					
42					
45					
48					
<p>T4006</p> <p>DOOR DRAWER GENERAL STORAGE TALL</p>		24	84	15.25 23.25 28.25	<p>HINGED DOORS FIXED CENTER FLOOR TWO ADJUSTABLE SHELVES ABOVE EIGHT EQUAL DRAWERS BELOW</p>
		27			
30					
33					
36					
39					
42					
45					
48					

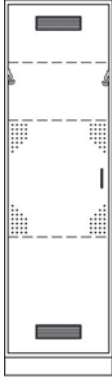
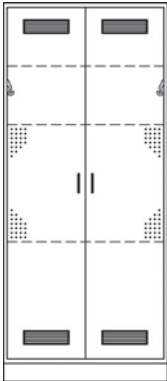
		WIDTHS	HEIGHTS	DEPTHS	DESCRIPTION
<p>T5001 HINGED LEFT</p> <p>T5002 HINGED RIGHT</p> <p>APRON SMOCK STORAGE TALL</p>		<p>18 21 24</p>	<p>84</p>	<p>23.25</p>	<p>HINGED DOOR FIXED SHELF TWO APRON CARRIERS (24) TOTAL HOOKS TWO LOUVERS</p>
<p>T5003</p> <p>APRON SMOCK STORAGE TALL</p>		<p>36 39 42 45 48</p>	<p>84</p>	<p>23.25</p>	<p>HINGED DOORS FIXED SHELF THREE APRON CARRIERS (36) TOTAL HOOKS FOUR LOUVERS</p>
<p>T5005 HINGED LEFT</p> <p>T5004 HINGED RIGHT</p> <p>APRON SMOCK STORAGE TALL</p>		<p>18 21 24</p>	<p>84</p>	<p>23.25</p>	<p>HINGED DOOR FIXED SHELF ADJUSTABLE SHELF FOUR APRON CARRIERS (48) TOTAL HOOKS TWO LOUVERS</p>

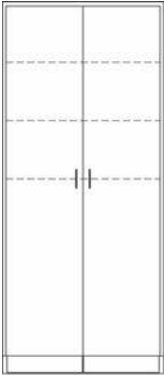
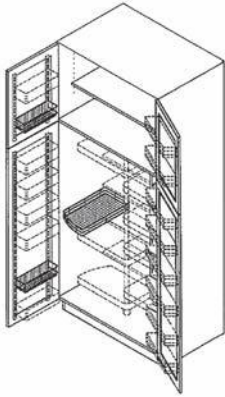
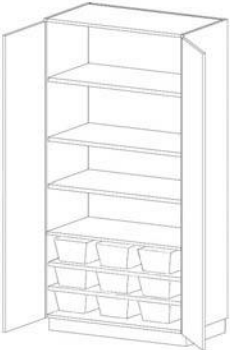

		WIDTHS	HEIGHTS	DEPTHS	DESCRIPTION
<p>T5006</p> <p>APRON SMOCK STORAGE TALL</p> 		<p>36 39 42 45 48</p>	84	23.25	<p>HINGED DOORS FIXED SHELF ADJUSTABLE SHELF SIX APRON CARRIERS (72) TOTAL HOOKS FOUR LOUVERS</p>
<p>T5007</p> <p>DISPLAY CASE</p> 		<p>24 27 30 33 36 39 42 45 48</p>	84	23.25	<p>SLIDING GLASS DOORS ABOVE HINGED DOORS BELOW THREE ADJUSTABLE GLASS SHELVES ADJUSTABLE SHELF FLUORESCENT LIGHT FIXTURE SWITCH CUTOUT W/BOX PLATE AND SWITCH NOT INCLUDED</p>
<p>T5008</p> <p>DISPLAY CASE</p> 		<p>24 27 30 33 36 39 42 45 48</p>	84	23.25	<p>SLIDING GLASS DOORS ABOVE HINGED DOORS BELOW THREE ADJUSTABLE GLASS SHELVES ADJUSTABLE SHELF</p>

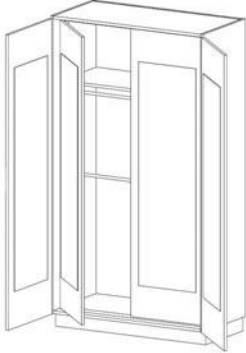
		WIDTHS	HEIGHTS	DEPTHS	DESCRIPTION
<p>T5009 HINGED LEFT</p> <p>T5010 HINGED RIGHT</p> <p>CLEANING STORAGE TALL</p>		<p>18 21 24</p>	<p>84</p>	<p>23.25</p>	<p>HINGED DOOR FIXED SHELF PARTIAL PEGBOARD INTERIOR FOUR SINGLE HOOKS TWO LOUVERS TWO BROOM CLIPS</p>
<p>T5011</p> <p>CLEANING STORAGE TALL</p>		<p>30 33 36 39 42 45 48</p>	<p>84</p>	<p>23.25</p>	<p>HINGED DOORS FIXED SHELF PARTIAL PEGBOARD INTERIOR FOUR SINGLE HOOKS TWO LOUVERS TWO BROOM CLIPS</p>
<p>T5013 HINGED LEFT</p> <p>T5012 HINGED RIGHT</p> <p>CART/TRASH STORAGE TALL</p>		<p>18 21 24</p>	<p>84</p>	<p>23.25</p>	<p>HINGED DOOR FIXED CENTER SHELF TWO ADJUSTABLE SHELVES INTEGRAL SUBBASE</p>

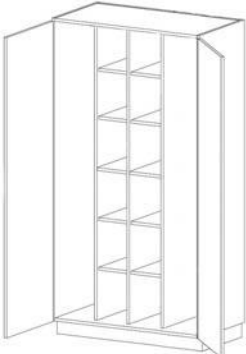
		WIDTHS	HEIGHTS	DEPTHS	DESCRIPTION
<p>T5014</p> <p>CLEANING STORAGE TALL</p> 	<p>24</p> <p>27</p> <p>30</p> <p>33</p> <p>36</p> <p>39</p> <p>42</p> <p>45</p> <p>48</p>	84	23.25	<p>HINGED DOORS</p> <p>FIXED CENTER SHELF</p> <p>TWO ADJUSTABLE SHELVES</p> <p>INTEGRAL SUBBASE</p>	
<p>T5020</p> <p>PANTRY STORAGE TALL</p> 	36	84	23.25	<p>HINGED DOORS</p> <p>ADJUSTABLE WIRE DOOR RACKS</p> <p>SHALLOW DEPTH SHELVING AT REAR</p> <p>SWING-OUT WIRE BASKETS</p> <p>ADJUSTABLE SHELF AT TOP</p>	
<p>T5021</p> <p>FOOD STAPLES STORAGE TALL</p> 	36	84	23.25	<p>HINGED DOORS</p> <p>FIXED SHELF</p> <p>STORAGE TOTES BELOW</p> <p>THREE ADJUSTABLE SHELVES</p>	

		WIDTHS	HEIGHTS	DEPTHS	DESCRIPTION		
T5022	FITTING MIRROR STATION TALL		42 45 48	84	23.25	HINGED DOORS HINGED MIRRORED INTERIOR DOORS FIXED SHELF CHROME HANGER ROD ADJUSTABLE CHROME HANGER ROD	
T5025 HINGED LEFT	T5024 HINGED RIGHT	IRONING CENTER STORAGE TALL		21 24	84	23.25	HINGED DOOR OFFSET VERTICAL PARTITION FIVE FIXED HEAT-RESIST SHELVES HOLDS FIVE IRONS HOLDS FIVE IRONING BOARDS
T5026	IRONING CENTER STORAGE TALL		39 42 45 48	84	23.25	HINGED DOOR THREE VERTICAL PARTITIONS TEN FIXED HEAT-RESIST SHELVES HOLDS TEN IRONS HOLDS TEN IRONING BOARDS	

SPECIALTY TALL CABINETS

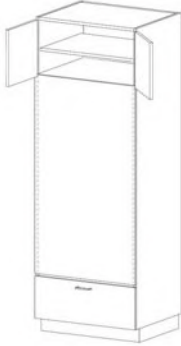
		WIDTHS	HEIGHTS	DEPTHS	DESCRIPTION
<p>T5050</p> <p>DOOR OVEN TALL</p> 		27	84	25.25	<p>HINGED DOORS AT TOP AND BOTTOM RAILS FOR OVEN MOUNTING SPECIFY OVEN CUTOUT SIZE ADJUSTABLE SHELF ABOVE & BELOW</p>
<p>T5051</p> <p>DOOR OVEN TALL</p> 		30 33 36	84	25.25	<p>HINGED DOORS AT TOP AND BOTTOM OVERLAY OVEN PANEL SPECIFY OVEN CUTOUT SIZE ADJUSTABLE SHELF ABOVE & BELOW</p>
<p>T5052</p> <p>DOOR DRAWER OVEN TALL</p> 		27	84	25.25	<p>HINGED DOORS AT TOP RAILS FOR OVEN MOUNTING SPECIFY OVEN CUTOUT SIZE DRAWER BELOW ADJUSTABLE SHELF ABOVE</p>

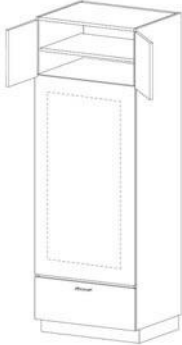
	WIDTHS	HEIGHTS	DEPTHS	DESCRIPTION
<p>T5053</p> <p>DOOR DRAWER OVEN TALL</p> 	<p>30 33 36</p>	<p>84</p>	<p>25.25</p>	<p>HINGED DOORS AT TOP OVERLAY OVEN PANEL SPECIFY OVEN CUTOUT SIZE DRAWER BELOW ADJUSTABLE SHELF ABOVE</p>

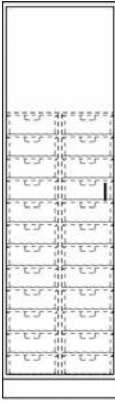
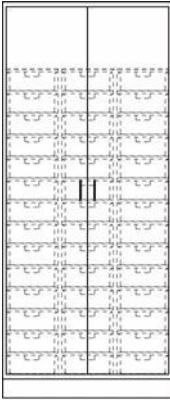
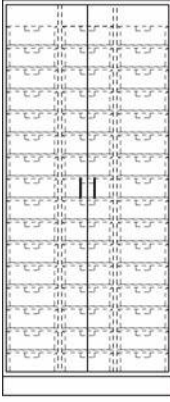
		WIDTHS	HEIGHTS	DEPTHS	DESCRIPTION
<p>T7001 HINGED LEFT</p> <p>T7002 HINGED RIGHT</p> <p>TOTE TRAY TALL</p> 		21 24	84	23.25	<p>HINGED DOOR FIXED TOP SHELF FIXED CENTER SHELF NOMINAL TOTE SIZES 21"- (24) 7.5" WIDE TOTE TRAYS 24"-(24) 9.5" WIDE TOTE TRAYS ORDER TOTES SEPARATELY</p>
<p>T7003</p> <p>TOTE TRAY TALL</p> 		36 39 42 45 48	84	23.25	<p>HINGED DOORS FIXED TOP SHELF FIXED CENTER SHELF NOMINAL TOTE SIZES 36"- (42) 9.5" WIDE TOTE TRAYS 39"-(42) 9.5" WIDE TOTE TRAYS 42"-(42) 9.5" WIDE TOTE TRAYS 45"-(42) 12.5" WIDE TOTE TRAYS 48"-(42) 12.5" WIDE TOTE TRAYS ORDER TOTES SEPARATELY</p>
<p>T7004</p> <p>TOTE TRAY TALL</p> 		36 39 42 45 48	84	23.25	<p>HINGED DOORS FIXED TOP SHELF FIXED CENTER SHELF NOMINAL TOTE SIZES 36"- (48) 9.5" WIDE TOTE TRAYS 39"-(48) 9.5" WIDE TOTE TRAYS 42"-(48) 9.5" WIDE TOTE TRAYS 45"-(48) 12.5" WIDE TOTE TRAYS 48"-(48) 12.5" WIDE TOTE TRAYS ORDER TOTES SEPARATELY</p>

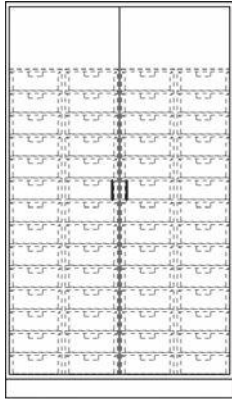
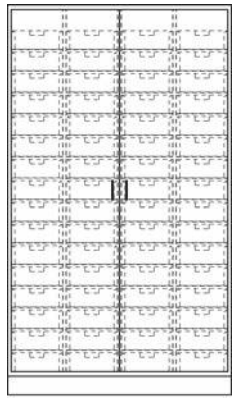
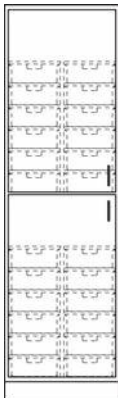
		WIDTHS	HEIGHTS	DEPTHS	DESCRIPTION
T7005 TOTE TRAY TALL		39	84	23.25	HINGED DOORS FIXED TOP SHELF FIXED CENTER SHELF NOMINAL TOTE SIZES 39"-(56) 7.5" WIDE TOTE TRAYS 42"-(56) 7.5" WIDE TOTE TRAYS 45"-(56) 7.5" WIDE TOTE TRAYS 48"-(56) 9.5" WIDE TOTE TRAYS ORDER TOTES SEPARATELY
		42			
45					
48					
T7006 TOTE TRAY TALL		39	84	23.25	HINGED DOORS FIXED TOP SHELF FIXED CENTER SHELF NOMINAL TOTE SIZES 39"-(64) 7.5" WIDE TOTE TRAYS 42"-(64) 7.5" WIDE TOTE TRAYS 45"-(64) 7.5" WIDE TOTE TRAYS 48"-(64) 9.5" WIDE TOTE TRAYS ORDER TOTES SEPARATELY
		42			
45					
48					
T7007 HINGED LEFT T7008 HINGED RIGHT SPLIT DOOR TOTE TRAY TALL		21 24	84	23.25	HINGED DOORS FIXED TOP SHELF FIXED CENTER FLOOR NOMINAL TOTE SIZES 21"-(24) 7.5" WIDE TOTE TRAYS 24"-(24) 9.5" WIDE TOTE TRAYS ORDER TOTES SEPARATELY

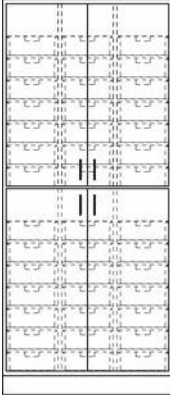
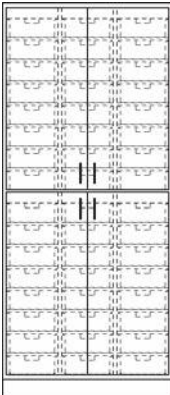
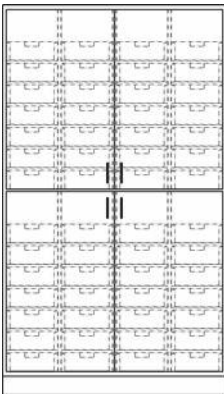
		WIDTHS	HEIGHTS	DEPTHS	DESCRIPTION
<p>T7009</p> <p>SPLIT DOOR TOTE TRAY TALL</p> 		36 39 42 45 48	84	23.25	<p>HINGED DOORS FIXED TOP SHELF FIXED CENTER SHELF NOMINAL TOTE SIZES 36"-(42) 9.5" WIDE TOTE TRAYS 39"-(42) 9.5" WIDE TOTE TRAYS 42"-(42) 9.5" WIDE TOTE TRAYS 45"-(42) 12.5" WIDE TOTE TRAYS 48"-(42) 13.5" WIDE TOTE TRAYS ORDER TOTES SEPARATELY</p>
<p>T7010</p> <p>SPLIT DOOR TOTE TRAY TALL</p> 		36 39 42 45 48	84	23.25	<p>HINGED DOORS FIXED TOP SHELF FIXED CENTER SHELF NOMINAL TOTE SIZES 36"-(48) 9.5" WIDE TOTE TRAYS 39"-(48) 9.5" WIDE TOTE TRAYS 42"-(48) 9.5" WIDE TOTE TRAYS 45"-(48) 12.5" WIDE TOTE TRAYS 48"-(48) 13.5" WIDE TOTE TRAYS ORDER TOTES SEPARATELY</p>
<p>T7011</p> <p>SPLIT DOOR TOTE TRAY TALL</p> 		39 42 45 48	84	23.25	<p>HINGED DOORS FIXED TOP SHELF FIXED CENTER SHELF NOMINAL TOTE SIZES 39"-(56) 9.5" WIDE TOTE TRAYS 42"-(56) 9.5" WIDE TOTE TRAYS 45"-(56) 12.5" WIDE TOTE TRAYS 48"-(56) 13.5" WIDE TOTE TRAYS ORDER TOTES SEPARATELY</p>

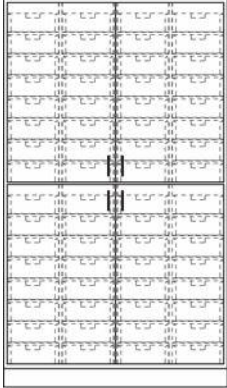
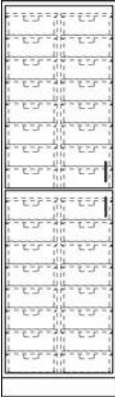
		WIDTHS	HEIGHTS	DEPTHS	DESCRIPTION		
T7012	SPLIT DOOR TOTE TRAY TALL		39 42 45 48	84	23.25	HINGED DOORS FIXED TOP SHELF FIXED CENTER SHELF NOMINAL TOTE SIZES 39"-(64) 7.5" WIDE TOTE TRAYS 42"-(64) 7.5" WIDE TOTE TRAYS 45"-(64) 7.5" WIDE TOTE TRAYS 48"-(64) 9.5" WIDE TOTE TRAYS ORDER TOTES SEPARATELY	
T7013 HINGED LEFT	T7014 HINGED RIGHT	SPLIT DOOR TOTE TRAY TALL		21 24	84	23.25	HINGED DOORS FIXED CENTER FLOOR NOMINAL TOTE SIZES 21"-(32) 7.5" WIDE TOTE TRAYS 24"-(32) 9.5" WIDE TOTE TRAYS ORDER TOTES SEPARATELY

Open Base Cabinets

B0000	Base Cabinet Modifier	2
B1001	No Shlvs	2
B1002	1 Adj Shelf	2
B1003	2 Adj Shlvs	2
B1063	Supply Storage, 1 Sliding Tray	3
B1064	Supply Storage, 2 Sliding Trays	3

Door Base Cabinets

B2041	1 Sliding Tray, Dbl Door	4
B2042	2 Sliding Trays, Dbl Door	4
B2043	3 Sliding Trays, Dbl Door	4
B2044	4 Sliding Trays, Dbl Door	4
B2045	5 Sliding Trays, Dbl Door	5
B2046	6 Sliding Trays, Dbl Door	5
B2001	1 Adj Shelf, Hinged Left	6
B2002	1 Adj Shelf, Hinged Right	6
B2003	2 Adj Shlvs, Hinged Left	6
B2004	2 Adj Shlvs, Hinged Right	6
B2005	1 Adj Shelf, Dbl Door	6
B2006	2 Adj Shlvs, Dbl Door	6
B2007	Center Partition, 2 Adj Shlvs, Dbl Door	7
B2008	Center Partition, 4 Adj Shlvs, Dbl Door	7
B2009	Project Storage, Hinged Left	7
B2010	Project Storage, Hinged Right	7
B2011	2 Partitions, 9 Adj Shlvs, Dbl Door	7

Drwr Base Cabinets

B3001	2 Eq Drwr, 1 Pull	8
B3002	2 Eq Drwr, 2 Pulls	8
B3003	3 Eq Drwr, 1 Pull	8
B3004	3 Eq Drwr, 2 Pulls	8
B3005	3 Drwr, 1 Pull	9
B3006	3 Drwr, 2 Pulls	9
B3007	4 Eq Drwr, 1 Pull	9
B3046	4 Eq Project Storage, 1 Pull	9
B3008	4 Eq Drwr, 2 Pulls	10
B3047	4 Eq Project Storage, 2 Pulls	10
B3009	5 Eq Drwr, 1 Pull	10
B3038	5 Eq Project Storage, 1 Pull	10
B3010	5 Eq Drwr, 2 Pulls	11
B3039	5 Eq Project Storage, 2 Pulls	11
B3011	5 Drwr, 1 Pull	11
B3012	5 Drwr, 2 Pulls	11
B3013	6 Eq Drwr, 1 Pull	12
B3040	6 Eq Project Storage, 1 Pull	12
B3014	6 Eq Drwr, 2 Pulls	12
B3041	6 Eq Project Storage, 2 Pulls	12
B3015	6 Eq Drwr, 1 Pull	13
B3016	6 Eq Drwr, Comp't At Top, 1 Pull	13
B3017	6 Drwr, 1 Pull	13
B3018	6 Drwr, 2 Pulls	13
B3019	7 Eq Drwr, 1 Pull	14
B3042	7 Eq Project Storage, 1 Pull	14
B3020	7 Eq Drwr, 2 Pulls	14
B3043	7 Eq Project Storage, 2 Pulls	14
B3021	7 Drwr, 1 Pull	15
B3022	7 Drwr, 2 Pulls	15
B3023	7 Drwr, 1 Pull	15
B3024	7 Drwr, 2 Pulls	15
B3025	7 Drwr, 1 Pull	16
B3026	7 Drwr, 2 Pulls	16

B3027	7 Drwr, 1 Pull	16
B3028	7 Drwr, 2 Pulls	16
B3029	8 Eq Drwr, 1 Pull	17
B3044	8 Eq Project Storage, 1 Pull	17
B3030	8 Eq Drwr, 2 Pulls	17
B3045	8 Eq Project Storage, 2 Pulls	17
B3031	8 Eq Drwr, 1 Pull	18
B3032	8 Drwr, 1 Pull	18
B3033	8 Drwr, 2 Pulls	18
B3034	8 Eq Drwr, 1 Pull	18
B3035	10 Drwr, 1 Pull	19
B3036	12 Eq Drwr, 1 Pull	19
B3037	16 Eq Drwr, 1 Pull	19

Combination Base Cabinets

B4001	1 Drwr, 1 Adj Shelf, Hinged Left	20
B4002	1 Drwr, 1 Adj Shelf, Hinged Right	20
B4003	1 Drwr, 1 Adj Shelf, Dbl Door, 1 Pull	20
B4004	1 Drwr, 1 Adj Shelf, Dbl Door, 2 Pulls	20
B4005	1 Drwr, Cntr Partition, 2 Adj Shlvs, Dbl Door, 1 Pull	20
B4006	1 Drwr, 2 Adj Shlvs, Dbl Door, 2 Pulls	21
B4007	2 Eq Drwr, 1 Adj Shelf, Dbl Door	21
B4008	2 Eq Drwr, 2 Adj Shlvs, Dbl Door	21

Sink Base Cabinets

B5001	Blank Head, Rem Back, Hinged Left	22
B5002	Blank Head, Rem Back, Hinged Right	22
B5017	Blank Head, Rem Back/Bot, Hinged Left	22
B5018	Blank Head, Rem Back/Bot, Hinged Right	22
B5003	Blank Head, Rem Back, Dbl Door	22
B5019	Blank Head, Rem Back/Bottom, Dbl Door	22
B5004	Head Rail, Rem Back, Hinged Right	23
B5005	Head Rail, Rem Back, Hinged Left	23
B5020	Head Rail, Rem Back/Bot, Hinged Right	23
B5021	Head Rail, Rem Back/Bot, Hinged Left	23
B5006	Head Rail, Rem Back, Dbl Door	23
B5022	Head Rail, Rem Back/Bottom, Dbl Door	23
B5007	Full Ht Door, Rem Back, Hinged Left	24
B5008	Full Ht Door, Rem Back, Hinged Right	24
B5023	Full Ht Door, Rem Back/Bot, Hinged Left	24
B5024	Full Ht Door, Rem Back/Bot, Hinged Right	24
B5009	Full Ht Door, Rem Back/Bot, Dbl Door	24
B5025	Full Ht Door, Rem Back/Bot, Hinged Right	24
B5010	Recessed Panel, Rem Back, Hinged Left	25
B5011	Recessed Panel, Rem Back, Hinged Right	25
B5026	Rec Panel, Rem Back/Bot, Hinged Left	25
B5027	Rec Panel, Rem Back/Bot, Hinged Right	25
B5012	Recessed Panel, Rem Back, Dbl Door	25
B5028	Rec Panel, Rem Back/Bot, Dbl Door	25
B5013	Blank Head, Rem Back, Hinged Left	26
B5014	Blank Head, Rem Back, Hinged Right	26
B5015	Full Ht Door, Rem Back, Hinged Left	26
B5016	Full Ht Door, Rem Back, Hinged Right	26
D5001	ADA Sink Panel Assembly	27
D5002	ADA Sink Panel Assembly	27
D5003	ADA Sink Panel Assembly	27
D5004	ADA Sink Panel Assembly	27
D5006	ADA Sink Panel Assembly, 29" Clearance	28
D5007	ADA Sink Panel Assembly, 29" Clearance	28
D5008	ADA Sink Panel Assembly, 29" Clearance	28
D5009	ADA Sink Panel Assembly, 29" Clearance	28
D5100	ADA Pocket Door Sink	29

D5130	ADA Pocket Door Sink, Convertible.....	29	B2063	Sewing Machine Unit, Hinged Left	41
D5140	ADA Pocket Door Sink, Convertible.....	29	B2064	Sewing Machine Unit, Hinged Right.....	41
B5210	Standard Sink Skirt Assembly	29	B2059	Stand Mixer, Hinged Left	41
D5210	ADA Sink Skirt Assembly.....	30	B2060	Stand Mixer, Hinged Right	41
B5250	Box Sink Skirt Assembly	30	B2081	Towel Storage Base, Hinged Left	41
Corner Base Cabinets			B2082	Towel Storage Base, Hinged Right	41
B6001	Open, 1 Adj Shelf	31	B2083	Tray Storage Base, Hinged Left	42
B6002	1 Adj Shelf, Hinged Right	31	B2084	Tray Storage Base, Hinged Right	42
B6003	1 Adj Shelf, Hinged Left	31	B2085	Sliding Utensil Storage Base	42
B6004	2 Revolving Shlvs, Hinged Right	31	B2086	Pantry Storage Base	42
B6005	2 Revolving Shlvs, Hinged Left	31	Open Wall Cabinets		
B6006	2 Revolving Shlvs, 2 Revolving Door	31	W0000	Wall Cabinet Modifier	43
B6007	3 Revolving Shlvs, 2 Revolving Door	32	W1001	Open, No Shelves	43
B6008	Dead Crnr, 2 Turnout Shlvs, Hinged Right	32	W1002	Open, 1 Adj Shelf	43
B6009	Dead Crnr, 2 Turnout Shlvs, Hinged Left	32	W1003	Open, 2 Adj Shelves	43
B6010	Dead Crnr, 2 Turnout Shlvs, Hinged Right	32	W1004	Open, 3 Adj Shelves	44
B6011	Dead Crnr, 2 Turnout Shlvs, Hinged Left	32	Door Wall Cabinets		
B6012	Dead Crnr, 1 Adj Shelf, Hinged Right	32	W2001	Hinged Left	44
B6013	Dead Crnr, 1 Adj Shelf, Hinged Left	32	W2002	Hinged Right	44
B6014	Dead Crnr, 1 Drwr, 1 Adj Shelf, Hinged Right	33	W2003	1 Adj Shelf, Hinged Left	44
B6015	Dead Crnr, 1 Drwr, 1 Adj Shelf, Hinged Left	33	W2004	1 Adj Shelf, Hinged Right	44
Tote Tray Base Cabinets			W2005	2 Adj Shelves, Hinged Left	44
B7001	3 Tote Trays, 1 Drwr, Hinged Left	34	W2006	2 Adj Shelves, Hinged Right	44
B7002	3 Tote Trays, 1 Drwr, Hinged Right	34	W2007	2 Adj Shelves, Hinged Left	45
B7003	4 Tote Trays, 1 Drwr, Hinged Left	34	W2008	2 Adj Shelves, Hinged Right	45
B7004	4 Tote Trays, 1 Drwr, Hinged Right	34	W2009	Double Dr	45
B7005	4 Tote Trays, Hinged Left	34	W2010	1 Adj Shelf, Double Dr	45
B7006	4 Tote Trays, Hinged Right	34	W2011	2 Adj Shelves, Double Dr	45
B7007	5 Tote Trays, Hinged Left	34	W2012	3 Adj Shelves, Double Dr	46
B7008	5 Tote Trays, Hinged Right	34	W2101	Framed Glass Dr Hinged Left	46
B7009	6 Tote Trays, Hinged Left	35	W2102	Framed Glass Dr Hinged Right	46
B7010	6 Tote Trays, Hinged Right	35	W2103	1 Adj Shelf, Framed Glass Dr Hinged Left	46
B7011	8 Tote Trays, Hinged Left	35	W2104	1 Adj Shelf, Framed Glass Dr Hinged Right	46
B7012	8 Tote Trays, Hinged Right	35	W2105	2 Adj Shelves, Framed Glass Dr Hinged Left	46
B7013	8 Tote Trays, Dbl Door	35	W2106	2 Adj Shelves, Framed Glass Dr Hinged Right	46
B7014	10 Tote Trays, Hinged Right	35	W2107	2 Adj Shelves, Framed Glass Dr Hinged Left	47
B7015	10 Tote Trays, Hinged Left	35	W2108	2 Adj Shelves, Framed Glass Dr Hinged Right	47
B7016	10 Tote Trays, Dbl Door	36	W2109	Framed Glass Double Dr	47
B7017	12 Tote Trays, Hinged Left	36	W2110	1 Adj Shelf, Framed Glass Double Dr	47
B7018	12 Tote Trays, Hinged Right	36	W2111	2 Adj Shelves, Framed Glass Double Dr	47
B7019	12 Tote Trays, Dbl Door	36	W2112	3 Adj Shelves, Framed Glass Double Dr	48
B7020	12 Tote Trays, Dbl Door	36	Corner Wall Cabinets		
B7021	15 Tote Trays, Dbl Door	37	W6001	Open, 1 Adj Shelf	48
B7022	16 Tote Trays, Dbl Door	37	W6002	Open, 2 Adj Shelves	48
B7023	18 Tote Trays, Dbl Door	37	W6003	Open, 3 Adj Shelves	48
B7024	20 Tote Trays, Dbl Door	37	W6004	1 Adj Shelf, Hinged Right	49
B7025	24 Tote Trays, Dbl Door	38	W6005	1 Adj Shelf, Hinged Left	49
Specialty Base Cabinets			W6006	2 Adj Shelves, Hinged Right	49
B1014	Right End-Cap Unit	39	W6007	2 Adj Shelves, Hinged Left	49
B1015	Left End-Cap Unit	39	W6008	3 Adj Shelves, Hinged Right	49
B1016	End-Cap Unit	39	W6009	3 Adj Shelves, Hinged Left	49
B1017	End-Cap Unit	39	W6102	1 Adj Shelf, Framed Glass Dr Hinged Right	49
B2030	Tilt-Out Waste	40	W6101	1 Adj Shelf, Framed Glass Dr Hinged Left	49
B2031	Slide-Out Waste	40	W6104	2 Adj Shelves, Framed Glass Dr Hinged Right	50
B2035	Flipper Door Waste, Hinged Left	40	W6103	2 Adj Shelves, Framed Glass Dr Hinged Left	50
B2036	Flipper Door Waste, Hinged Right	40	W6106	3 Adj Shelves, Framed Glass Dr Hinged Right	50
B2037	Grommet Waste, Hinged Left	40	W6105	3 Adj Shelves, Framed Glass Dr Hinged Left	50
B2038	Grommet Waste, Hinged Right	40	W6010	2 Revolving Shelves, Hinged Right	50
B2039	Open Waste, Hinged Left	41	W6011	2 Revolving Shelves, Hinged Left	50
B2040	Open Waste, Hinged Right	41	W6012	3 Revolving Shelves, Hinged Right	50

W6013	3 Revolving Shelves, Hinged Left.....	50
W6014	4 Revolving Shelves, Hinged Right.....	51
W6015	4 Revolving Shelves, Hinged Left.....	51
W6016	2 Revolving Shelves, 2 Double Revolving Dr	51
W6017	3 Revolving Shelves, 2 Double Revolving Dr	51
W6018	4 Revolving Shelves, 2 Double Revolving Dr	51
W6019	Dead Crnr, Dr Hinged Left.....	52
W6020	Dead Crnr, Dr Hinged Right.....	52
W6021	Dead Crnr, 1 Adj Shelf, Dr Hinged Left	52
W6022	Dead Crnr, 1 Adj Shelf, Dr Hinged Right.....	52
W6023	Dead Crnr, 2 Adj Shelves, Dr Hinged Left	52
W6024	Dead Crnr, 2 Adj Shelves, Dr Hinged Right.....	52
W6025	Dead Crnr, 3 Adj Shelves, Dr Hinged Left	52
W6026	Dead Crnr, 3 Adj Shelves, Dr Hinged Right.....	52
W6107	Dead Crnr, Framed Glass Dr Hinged Left	53
W6108	Dead Crnr, Framed Glass Dr Hinged Right.....	53
W6109	Dead Crnr, 1 Adj Shelf, Framed Glass Dr Hinged Left	53
W6110	Dead Crnr, 1 Adj Shelf, Framed Glass Dr Hinged Right	53
W6111	Dead Crnr, 2 Adj Shelves, Framed Glass Dr Hinged Left	53
W6112	Dead Crnr, 2 Adj Shelves, Framed Glass Dr Hinged Right	53
W6113	Dead Crnr, 3 Adj Shelves, Framed Glass Dr Hinged Left	53
W6114	Dead Crnr, 3 Adj Shelves, Framed Glass Dr Hinged Right	53
W6027	Dead Crnr, Double Dr	54
W6028	Dead Crnr, Double Dr	54
W6029	Dead Crnr, 1 Adj Shelf, Double Dr.....	54
W6030	Dead Crnr, 1 Adj Shelf, Double Dr	54
W6031	Dead Crnr, 2 Adj Shelves, Double Dr	54
W6032	Dead Crnr, 2 Adj Shelves, Double Dr	54
W6033	Dead Crnr, 2 Adj Shelves, Double Dr	54
W6034	Dead Crnr, 2 Adj Shelves, Double Dr	54
W6115	Dead Crnr, Framed Glass Double Dr	55
W6116	Dead Crnr, Framed Glass Double Dr	55
W6117	Dead Crnr, 1 Adj Shelf, Framed Glass Double Dr.....	55
W6118	Dead Crnr, 1 Adj Shelf, Framed Glass Double Dr	55
W6119	Dead Crnr, 2 Adj Shelves, Framed Glass Double Dr.....	55
W6120	Dead Crnr, 2 Adj Shelves, Framed Glass Double Dr.....	55
W6121	Dead Crnr, 3 Adj Shelves, Framed Glass Double Dr.....	55
W6122	Dead Crnr, 3 Adj Shelves, Framed Glass Double Dr.....	55
W3001	Open Microwave	56
W3002	Open Microwave, Double Dr	56
Open Tall Cabinets		
T0000	Tall Cabinet Modifier.....	57
T1001	1 Fixed Center Shelf, 2 Adj Shlvs.....	57
T1002	1 Fixed Center Shelf, 4 Adj Shlvs.....	57
T1003	Center Partition, 2 Fixed Center Shlvs, 4 Adj Shlvs.....	58
T1004	Center Partition, 2 Fixed Center Shlvs, 8 Adj Shlvs.....	58
Door Tall Cabinets		
T2001	1 Fixed Center Shelf, 4 Adj Shlvs, Dr Hinged Left	59
T2002	1 Fixed Center Shelf, 4 Adj Shlvs, Dr Hinged Right	59
T2101	1 Fixed Center Shelf, 4 Adj Shlvs, Frmd Glass Dr Hinged Left	59
T2102	1 Fixed Center Shelf, 4 Adj Shlvs, Frmd Glass Dr Hinged Right.....	59
T2003	1 Fixed Center Shelf, 4 Adj Shlvs, Dbl Dr	59
T2103	1 Fixed Center Shelf, 4 Adj Shlvs, Framed Glass Dbl Dr.....	60
T2004	Center Partition, 2 Fixed Center Shlvs, 8 Adj Shlvs, Dbl Dr	60
T2005	1 Fixed Floor, 4 Adj Shlvs, Split Drs Hinged Left	60
T2006	1 Fixed Floor, 4 Adj Shlvs, Split Drs Hinged Right.....	60
T2007	1 Fixed Floor, 4 Adj Shlvs, Dbl Split Drs	61
T2008	3 Partitions, 4 Fixed Center Shlvs, 16 Adj Shlvs, Dbl Drs	61
Teacher Wardrobe Cabinets		
T3001	1 Fixed Shelf, Hanger Rod, Mirror, Pin Tray, Dr Hinged Left	62
T3002	1 Fixed Shelf, Hanger Rod, Mirror, Pin Tray, Dr Hinged Right	62
T3003	2 Fixed Shlvs, 2 Adj Shlvs, Rod, Mir, Pin Tray, Dbl Dr	62
T3004	2 Fixed Shlvs, 2 Adj Shlvs, Rod, Mir, Pin Tray, Dbl Dr	62
T3005	2 Fxd & 1 Adj Shlf, Rod, Mir, Pin Tray, 2 Files, Dbl Dr	63
T3006	2 Fxd & 1 Adj Shlf, Rod, Mir, Pin Tray, 2 Files, Dbl Dr	63
T3007	2 Fxd & 1 Adj Shlf, Rod, Mir, Pin Tray, 2 Files, 1 Drwr, Dbl Dr ..	63
T3008	2 Fxd & 1 Adj Shlf, Rod, Mir, Pin Tray, 2 Files, 1 Drwr, Dbl Dr ..	64
T3009	1 Fxd Shlf, 2 Adj Shlvs, Rod, Mir, Pin Tray, 3 Ext Files, Dbl Dr ...	64
T3010	1 Fxd Shlf, 2 Adj Shlvs, Rod, Mir, Pin Tray, 3 Ext Files, Dbl Dr ...	64
T3011	Fxd Shlf, Fxd Flr, 4 Adj Shlvs, Rod, Mir, Pin Tray, Split Dbl Dr ...	65
T3012	Fxd Shlf, Fxd Flr, 4 Adj Shlvs, Rod, Mir, Pin Tray, Split Dbl Dr ...	65
T3013	1 Fixed Shelf, Hanger Rod, Adj Hanger Rod, Door Hinged Left ...	65
T3014	1 Fixed Shelf, Hanger Rod, Adj Hanger Rod, Door Hinged Right...	65
T3015	1 Fixed Shelf, Hanger Rod, Adj Hanger Rod, Dbl Dr.....	66
T3021	1 Fixed Floor, 3 Adj Shlvs, 2 Drwrs Below, Door Hinged Left	66
T3022	1 Fixed Floor, 3 Adj Shlvs, 2 Drwrs Below, Door Hinged Right....	66
T3023	1 Fixed Floor, 3 Adj Shlvs, 2 Drwrs Below, Dbl Dr.....	66
T3024	1 Fixed Floor, 3 Adj Shlvs, 2 Drwrs Below, Dbl Dr.....	67
Combination Tall Cabinets		
T4001	1 Fixed Floor, 2 Adj Shlvs, 4 Drwrs Below, Door Hinged Left	68
T4002	1 Fixed Floor, 2 Adj Shlvs, 4 Drwrs Below, Door Hinged Right....	68
T4003	1 Fixed Floor, 2 Adj Shlvs, 4 Drwrs Below, Dbl Door	68
T4004	1 Fixed Floor, 2 Adj Shlvs, 4 Drwrs Below, Dbl Door	68
T4005	1 Fixed Floor, 2 Adj Shlvs, 8 Drwrs Below, Dbl Door	69
T4006	1 Fixed Floor, 2 Adj Shlvs, 8 Drwrs Below, Dbl Door	69
Specialty Tall Cabinets		
T5001	Apron/Smock Storage, 2 Louvers, 2 Carriers, Door Hinged Left ..	70
T5002	Apron/Smock Storage, 2 Louvers, 2 Carriers, Door Hinged Right ..	70
T5003	Apron/Smock Storage, 4 Louvers, 3 Carriers, Dbl Door	70
T5005	Apron/Smock Storage, 2 Louvers, 4 Carriers, Door Hinged Left ..	70
T5004	Apron/Smock Storage, 2 Louvers, 4 Carriers, Door Hinged Right ..	70
T5006	Apron/Smock Storage, 4 Louvers, 6 Carriers, Dbl Door	71
T5007	Display Case, 3 Adj Glass Shlvs, Glass Drs, Box, Light, Dbl Door ..	71
T5008	Display Case, 3 Adj Glass Shlvs, Glass Drs, Dbl Door	71
T5009	Cleaning Storage, Partial Peg Int, 2 Louvers, 4 Hooks, Door HL...	72
T5010	Cleaning Storage, Partial Peg Int, 2 Louvers, 4 Hooks, Door HR ..	72
T5011	Cleaning Storage, Partial Peg Int, 4 Louvers, 4 Hooks, Dbl Door ...	72
T5013	Cart/Trash Storage, Integral Subbase, 2 Adj Shelves, Door HL.....	72
T5012	Cart/Trash Storage, Integral Subbase, 2 Adj Shelves, Door HR	72
T5014	Cart/Trash Storage, Integral Subbase, 2 Adj Shelves, Dbl Door	73
T5020	Pantry, Adj Wire Racks, Pivoting Wire Racks, Split Dbl Door	73
T5021	Pantry, Fixed Shelf, 3 Adj Shelves, 9 Baskets Below, Dbl Door	73
T5022	Fxd Shelf, Hanger Rod, Adj Hanger Rod, Dbl Mirror Dr, Dbl Dr ..	74
T5025	Ironing Cntr Storage, Heat-Resist Shelves, Door Hinged Left.....	74
T5024	Ironing Cntr Storage, Heat-Resist Shelves, Door Hinged Right	74
T5026	Ironing Cntr Storage, Heat-Resist Shelves, Dbl Door.....	74
T5050	Oven Cabinet, Adj Shelf, Rail Oven Mounting, Dbl Door	75
T5051	Oven Cabinet, Adj Shelf, Overlay Oven Mounting, Dbl Door	75
T5052	Oven Cabinet, Drawer, Rail Oven Mounting, Dbl Door.....	75
T5053	Oven Cabinet, Drawer, Overlay Oven Mounting, Dbl Door	76
Tote Tray Tall Cabinets		
T7001	24 Tote Trays, Fixed Shelf, Door Hinged Left	77
T7002	24 Tote Trays, Fixed Shelf, Door Hinged Right.....	77
T7003	42 Tote Trays, Fixed Shelf, Dbl Door	77
T7004	48 Tote Trays, Fixed Shelf, Dbl Door	77
T7005	56 Tote Trays, Fixed Shelf, Dbl Door	78
T7006	64 Tote Trays, Fixed Shelf, Dbl Door	78
T7007	24 Tote Trays, Fixed Floor, Split Door Hinged Left	78
T7008	24 Tote Trays, Fixed Floor, Split Door Hinged Right	78
T7009	42 Tote Trays, Fixed Floor, Split Dbl Door	79
T7010	48 Tote Trays, Fixed Floor, Split Dbl Door.....	79
T7011	56 Tote Trays, Fixed Floor, Split Dbl Door.....	79
T7012	64 Tote Trays, Fixed Floor, Split Dbl Door.....	80
T7013	32 Tote Trays, Fixed Floor, Split Door Hinged Left	80
T7014	32 Tote Trays, Fixed Floor, Split Door Hinged Right.....	80

PART 1: DESCRIPTION OF WORK

1.00 SUMMARY AND SCOPE

A. Section Includes:

1. All cabinets and casework, including tops, ledges, supporting structures, and miscellaneous items of equipment as listed in these specifications, or equipment schedules including delivery to the building, setting in place, leveling, scribing to walls and floors as required. Furnish and install all filler panels, knee space panels and scribes as shown on drawings.
2. Furnish and deliver all utility service outlet accessory fittings, electrical receptacles and switches, as listed in these specifications, equipment schedules or as shown on drawings as mounted on the laboratory furniture. Items shall be furnished with supply tank nipples and lock nuts, loose in boxes and properly marked. All plumbing and electrical fittings will be packaged separately and properly marked for delivery to the appropriate contractor.
3. Furnish and deliver, packed in boxes for installation by the mechanical contractor, all laboratory sinks, cup sinks or drains, drain troughs, overflows and sink outlets with integral tailpieces, which occur above the floor and where these items are part of the equipment or listed in the specifications, equipment schedules or shown on the drawings. Integral tailpieces when required shall be in accordance with the manufacturer's standards. All tailpieces shall be furnished less the couplings required to connect them to the drain piping system.
4. Furnish service strip supports and set in place service tunnels, service turrets, supporting structures and reagent racks of the type shown on the details.
5. Remove of all debris, dirt and rubbish accumulated as a result of the installation of the science casework to an onsite container provided by others, leaving the premises clean and orderly.

B. Related Divisions:

1. Divisions 5 & 6 : Behind-the-Wall Blocking and Studs
2. Division 9 : Base Molding
3. Division 11: Chemical Fume Hoods
4. Division 15 : Plumbing
5. Division 16 : Electrical Fittings and Connections

C. Related Publications:

1. Architectural Woodwork Institute, Architectural Woodwork Standards, Latest Edition
2. NFPA 30 - National Fire Protection Association
3. NFPA-45 - National Fire Protection Association

4. UL - Underwriters Laboratory
5. ASTM D552 - Bending Test
6. Scientific Equipment & Furniture Association Casework Recommended Practices (SEFA 8)

1.01 BASIS OF WORK

- A. This specification uses Labscape majestic style (reveal overlay) as the standard of construction for science casework. The construction standards of this product line shall provide the basis for quality and functional installation.
- B. Supply all equipment in accordance with this specification. No alternates, deviations or exceptions to the specified construction or materials are allowed.
- C. The owner / owner representative reserves the right to reject qualified or alternate proposals and to award based on product value where such action assures the owner greater integrity of product.

1.02 QUALITY ASSURANCE

- A. The wood science casework contractor shall also provide work tops and fume hoods to assure proper staging, shipment and single source responsibility. .
- B. Each cabinet shall be foam and stretch wrapped to ensure cabinet surfaces are protected until the time of installation. Blanket-wrap is not allowed unless the blankets remain behind after delivery to assure the cabinets remain scratch-, grease- and dirt-free before installation.
- C. Majority of the wood used shall be from a certified sustainable source. Certification shall be by a third-source party, such as meeting the requirements of the Sustainable Forestry Initiative or the Forest Stewardship Council.

1.03 SUBMITTALS

- A. Submit manufacturer's data and installation instructions for each type of casework.
- B. Casework samples will be required and reviewed per specification. Samples shall be delivered, at no cost to the architect or owner, to a destination set forth by the architect or owner. This must be done seven (7) days before quotation deadline as a condition of approval of each bidder. Samples shall be full size, production type samples as will be delivered for the project. Furnish the following:
 1. One combination drawer and cupboard base unit, including one shelf.
 2. One sample of all top materials shown or called for.
 3. Sample of all mechanical service fittings, locks, door pulls, hinges, and interior hardware.

- E. Submit shop drawings for furniture assemblies showing plans, elevations, ends, cross-sections, service run spaces, location and type of service fittings.
- 1. Coordinate shop drawings with other work involved.
- 2. Provide roughing-in drawings for mechanical and electrical services when required.

PART 2: PRODUCTS

2.00 MANUFACTURERS

- A. The basis of this specification is Labscape wood science casework. No exceptions, deviations or alternates to the specified construction or materials are allowed.
- B. Lifetime warranty: The selected manufacturer must warrant for the life of the product in the application and location installed, starting at the date of acceptance or occupancy, whichever comes first, that all products sold under the contract referenced above shall be free from defects in material and workmanship. Purchaser shall notify the manufacturer's representative immediately of any defective product. The manufacturer shall have a reasonable opportunity to inspect the goods. The purchaser shall return no product until receipt by purchaser of written shipping instructions from the manufacturer.
- C. All manufacturers must submit samples in accordance with this specification.
- D. The architect will impound the above samples of the successful manufacturer or owner to insure that material delivered to the jobsite conforms in every respect to the samples submitted.

2.01 MATERIALS

- A. This specification is to ensure wood cabinets specifically designed for the science environment.
- B. Hardwood shall be kiln-dried, clear, free of defects, and meet surface requirements as specified.
- C. Plywood shall be balanced construction and 3/4" 7-ply veneer core hardwood plywood for shelves, cabinet ends and bottoms of base and tall cabinets; 1" 9-ply veneer core hardwood plywood for shelves over 36", bottoms of wall and upper cabinets, and tops of wall, upper and tall cabinets; nominal 1/2" 9-ply veneer core plywood for drawer body; 3/4" 3-ply particleboard core plywood for cabinet doors and drawer heads. Plywood shall meet the standards of ANSI/HPVA HP-1-latest.
- D. Casework parts shall be as defined in AWI Architectural Woodwork Standards, latest edition.
- E. Exposed surfaces shall be hand selected plain-sliced, HPVA face grade Red Oak veneers and compatible Grade I Red Oak hardwood lumber. (All exterior surfaces are considered exposed, including end panels abutting other cabinets, wall or other objects, and the backs of doors. Cabinet backs are considered concealed unless visible to view.)
- F. Semi-exposed surfaces shall be hand selected HPVA face grade Birch veneers and compatible Grade II hardwood lumber.

- G. Concealed surfaces shall be no less than HPVA grade D face or grade 3 back veneers and compatible mill option hardwood lumber.
- H. All visible edges will be edgebanded (min 3 mm for door/drawer fronts) with compatible hardwood Red Oak.
- I. Hardboard shall be 1/4" thick 55 lb. density hardwood chip fiberboard formed with heat and pressure into sheets providing a hard, smooth surface.
- J. Glass used for framed sliding and swinging doors shall be 3/16" tempered glass. Glass used for unframed sliding doors, shall be 1/4" tempered glass.
- K. Drawer and door pulls shall be satin finish, zinc coated wire type, 96 mm centers, offering a comfortable hand grip, and be securely fastened to doors and drawers. Two pulls shall be required on all drawers over 24" long.
- L. Hinges shall be BHMA Grade 1, five (5) knuckle institutional, .083" thick, offset type for all swinging doors. Hinges shall be 2- 1/2" long, one (1) pair for doors under 4 ft. in height and 1-1/2 pair on doors over 4 ft. in height. Hinges are mounted with flathead screws, so applied to door and cabinet to withstand a weight load of 150 lbs. minimum.
- M. Locks when shown or called for shall be a National Lock, 5-disc tumbler with heavy duty interchangeable cylinder. Exposed lock noses shall be dull nickel (satin). Locks shall have capacity for 200 primary key changes. Master key one level with the potential of 200 different, non-interchangeable master key groups.
- N. Roller catches shall be used on swinging doors. Catches shall have two spring-loaded polyethylene rollers and metal catch to secure doors. Double doors without locks shall have a catch on each door. Full height cases shall have 3-point latching devices. Magnetic catches are not allowed.
- O. Leg shoes shall be provided on all table legs, unless otherwise specified, to conceal leveling device. Shoes shall be 2-1/2" high and made of pliable, black rubber material. Use of a leg shoe, which does not conceal leveling device, will not be acceptable.
- P. Floor glides, where specified for movable open-leg tables, shall be a non-skid material at least 1" diameter to prevent indenting composition flooring and shall have at least a 5/8" height adjustment. Use of metal buttons will not be acceptable.
- Q. Dowels used to join frames and panels shall be fluted hardwood not less than 8 mm in diameter. Pre-glued dowels are not acceptable unless supported with non-visible mechanical fasteners; otherwise only wet glue is to be used to ensure adhesion.
- R. Shelf support clips shall be "seismic" twin pin type for mounting on interior of cabinet work. Clips shall be corrosion resistant and shall retain shelves from accidental removal. Shelves in all cabinets are adjustable on 32mm centers. Single pin support clips and surface mounted metal support strips and clips subject to corrosion are not acceptable.
- S. Base molding shall be provided by others.
- T. Upright rods, cross rods, and ring support rods, where specified, shall be aluminum (1/2" or 3/4" dia., as required). Rod sockets shall be aluminum, secured through table tops with lock nut and washer. Rod clamps shall be heavy duty, designed to securely hold rod assembly in any position. Use of wood rod assemblies will not be accepted.
- U. Label holders, where shown or called for, shall be a zinc-plated steel, brad-attached type with satin finish and designed for 2" x 1" cards.
- V. Number plates, where shown or called for, shall be aluminum brad-attached type with satin finish and indented black lettering.

W. Sink supports, where required, shall be of a cradle type consisting of two 1-1/2" x 3/4" horizontal cleats and adjustable leveling bolts or glides. The horizontal cleats shall be supported by two 1/8" x 1-1/2" angle irons attached to the cabinet end panels.

2.02 CONSTRUCTION

A. Open-leg Tables: Legs shall be Red Oak hardwood construction, 2-1/4" square with 1/4" radius on all corners. Legs shall be secured to the apron frame by a heavy-duty corner bolt and a 13-gauge steel corner brace. Corner braces shall be locked into apron rails by accurately located grooves and shall be securely fastened with screws. All apron rails shall be 13/16" thick solid Red Oak. Top shall be attached using zinc coated screws through pocket holes in the apron. Leg stretchers, where required, shall be 7/8" x 2-1/2", secured with a 4" long through-bolt.

B. Base Cabinets shall consist of the following minimum construction:

1. Joinery must meet AWI Premium Grade requirements.
2. End panels are multiple doweled on 64mm centers and glued to sub-top, intermediate rails and bottoms.
3. Cabinet bottoms shall be multiple doweled on 64mm centers and glued to end panels.
4. Toe space shall be 4" high and fully enclosed.
5. Edging shall be provided on the front edges of ends, bottoms, tops and shelves, and on all four edges of door and drawer fronts.
6. Sub-top panel shall be 3/4" veneer core plywood, multiple doweled on 64mm centers, screwed and glued to end panels.
7. Intermediate rails (3/4" x 2-1/2" hardwood per parts definition) shall be multiple doweled and glued to end panels at the front of the cabinet between drawers and between drawers and doors.
8. Screw strips (3/4" by 3" veneer core hardwood plywood) shall be located at the top and bottom behind the cabinet back and multiple doweled to the cabinet ends.
9. Hardboard cabinet backs shall be fully captured and dadoed into end panels and bottoms, with full perimeter gluing around the rear of the back. Where a removable back is indicated, it shall be an additional piece applied to cover an opening that is added to the fully captured back. (Backs are to meet the visual requirement of cabinet parts.)
10. Shelves shall be 3/4" thick in cabinets less than 36" wide, 1" thick in all cabinets 36" wide and greater. (Front edges of shelves are to meet the visual requirement of cabinet parts.)
11. Drawer box shall be:
 - a) Four-sided (sub-front, sides and back) of nominal 1/2" thick, 9-ply Baltic Birch plywood.
 - b) Adjacent panels shall be joined by fully glued multiple dovetail joinery all four corners.
 - c) Drawer box shall fill drawer opening vertically as much as is possible and still allow removal of the drawer.
 - d) Drawer box front-to-back depth must extend to within 1-1/2" of the cabinet back panel.
 - e) Drawer bottom (6mm on drawers under 42" wide, 12 mm on larger drawers) shall be dadoed into all four drawer box sides with full perimeter gluing on the underside.

12. Door and drawer heads shall be 3/4" thick plywood with edging as specified to resist warping. Reveals shall be 1/4" between door and drawer heads and 1/2" on end panels. Face veneer grain shall be matched vertically on doors and drawer heads on each individual cabinet.
13. Drawer slides shall be full extension, easily removable with a 100 lb. dynamic load rating and nylon roller bearings, powder coated surfaces, self-closing and with hold-open feature. File drawers shall be full extension, 150 lb. dynamic load rating mounted to the drawer sides.

C. Full Height Sliding Door Cases:

1. Shall be designed and constructed for full enclosure to assure dust proofing of the interior.
2. Tops shall be 1" thick plywood, multiple doweled into end panels, secured with glue.
3. A double extruded aluminum track shall be attached to the case top for suspension system when sliding doors are called for. Doors shall be suspended from an adjustable hanger and glide on nylon roller wheels. An aluminum U-channel is located on the case bottom to guide the bottom of the doors.
4. Solid panel doors shall be 3/4" thick plywood with edging as specified.
5. Glazed doors shall have 2-3/4" x 3/4" thick framing, mortised, tenoned, and glued. Glass shall be set into door frame and secured with a plastic retainer.
6. Doors shall be removable without use of tools, and so designed to prevent by-passing.
7. Shelves shall be 3/4" thick in cabinets less than 36" wide, 1" thick in all cabinets 36" wide and greater.
8. To assure a rigid case, the center shelf is structurally joined to the end panels and glued.
9. Case bottoms shall be 3/4" thick plywood, multiple doweled and glued securely to end panels.
10. Fastening cleats, top and bottom, 3/4" x 3" plywood, shall support and strengthen all joints.
11. Toe space, 2-1/4" deep x 4" high, shall be totally enclosed by a 3/4" x 4" plywood rail.
12. Backs in open and glazed door cases shall be 1/4" plywood; backs not exposed to view shall be 1/4" high-density fiberboard.
13. Case interior shall be flush.

D. Full Height Swinging Door Cases: General construction features shall be the same as for sliding door cases except for the following:

1. Doors shall overlap opening on all four sides
2. Astragal applied to left hand door shall provide further dust proofing.

E. Wall-Hung Sliding Door Cases: General construction features shall be the same as for full height type cases with the following exception:

1. Case bottoms shall be 1" thick plywood, multiple doveled on 64mm centers and glued securely to end panels.
- F. Wall Hung Swinging Door Cases: Construction and materials shall be the same as for sliding door cases with the following exceptions:
1. Panel or glass framed doors shall be hung on 1 pair of offset, institutional type hinges under 48" in height. Doors on cases 48" high shall have 1-1/2 pair of offset, institutional type hinges.
 2. All doors shall overlap opening four sides.
 3. Astragal applied to left hand door shall provide further dust proofing.

2.03 FINISH AND PERFORMANCE REQUIREMENTS

- A. Wood Surface Preparation: Prior to application of the wood finish, case and cabinet surfaces shall be smoothly sanded to remove loose fibers, scratch marks and abrasions, with all dust thoroughly removed by compressed air.
- B. Wood Stain Color: Clear coated, natural wood finish.
- C. Wood Finish Application: High solids, cross-linked, ultraviolet light (UV) cured "flat-line" coating developed for durability, including abrasion, chemical (acid, alkali and solvent), water, impact and scratch resistance, for flat-line applications. Coatings shall have little or no VOCs. Finish shall meet both AWI section 1500 and SEFA 8 W-2010 requirements.
- D. Finish shall be applied to cabinet parts prior to assembly in order to assure uniform coverage.

2.04 WORK SURFACES

- A. Materials: 1" Epoxy Resin, with alternate for 3/4" phenolic resin.

2.05 SINKS, CUPS, SINKS, AND DRAINS

- A. Sinks: Molded Epoxy Resin or polyolefin.

2.06 FITTINGS

- A. WaterSaver brand or equivalent
- B. Materials: Chrome-plated red brass or bronze
- C. Construction:

1. Valves:
 - a. Front-loaded valves
 - 1) Water
 - 2) Ball valve dry service
 - b. Rod-driven remote control valves for fume hoods
 - 1) Water
 - 2) Needle valve dry service
2. Water Outlets
 - a. Goosenecks
 - b. Aerator outlets
 - c. Tank nipples
 - d. Sink outlets
3. Miscellaneous
 - a. Crumb cup strainers
 - b. Vacuum breakers

PART 3: EXECUTION - LABORATORY CASEWORK AND RELATED PRODUCTS

3.00 SITE EXAMINATION

- A. The owner and/or his representative shall assure all building conditions conducive to the installation of a finished goods product; all critical dimensions and conditions previously checked have been adhered to by other contractors (general, mechanical, electrical, etc.) to assure a quality installation.

3.01 INSTALLATION

- A. Preparation: Prior to beginning installation of casework, check and verify that no irregularities exist that would affect quality of execution of work specified.
- B. Coordination: Coordinate the work of the Section with the schedule and other requirements of other work being performed in the area at the same time both with regard to mechanical and electrical connections to and in the fume hoods and the general construction work.

C. Installation shall be completed in accordance with SEFA 2-2010.

D. Performance:

1. Casework:

- a. Set casework components plumb, square, and straight with no distortion and securely anchor to building structure. Shim as required using concealed shims.
- b. Screw continuous cabinets together with joints flush, tight and uniform, and with alignment of adjacent units within 1/16" tolerance.
- c. Secure wall cabinets to solid supporting material, not to plaster, lath or gypsum board.
- d. Abut top edge surfaces in one true plane. Provide flush joints not to exceed 1/8" between top units.

2. Work surfaces:

- a. Where required due to field conditions, scribe to abutting surfaces.
- b. Only factory prepared field joints, located per approved shop drawings, shall be permitted. Secure the joints in the field, where practical, in the same manner as in the factory.
- c. Secure work surfaces to casework and equipment components with materials and procedures recommended by the manufacturer.

E. Adjust and Clean:

1. Repair or remove and replace defective work, as directed by owner and/or his representative upon completion of installation.
2. Adjust doors, drawers and other moving or operating parts to function smoothly.
3. Clean shop finished casework; touch up as required.
4. Clean work surfaces and leave them free of all grease and streaks.
5. Casework to be left broom clean and orderly.

F. Protection:

1. Provide reasonable protective measures to prevent casework and equipment from being exposed to other construction activity.
2. Advise owner and/or his representative of procedures and precautions for protection of material, installed laboratory casework and fixtures from damage by work of other trades.



DISTRIBUTED BY LONGO ASSOCIATES, INC.
WWW.LONGOLABS.COM